

Is this Ewe for You?

A New Design

One fundamental of directive wire-



antenna design is that two or more parallel wires carrying similar RF currents produce directivity regardless of the phase or amplitude of the currents, if the wires are separated significantly (greater than 0.05λ). I surmised that if a short wire (less than $1/4 \lambda$) were formed as an upside-down **U** and fed against ground, good F/B directivity would result.

Using Brian (K6STI) Beezley's *AO* software, I modeled such an antenna (with a terminating resistor to ground at the far end of the wire). Success was immediate, with F/B ratios greater than 30 dB predicted. Since *AO* assumes that the ground beneath the antenna is perfectly conducting, the initial result was suspect.

I loaded the *AO* dimensions into K6STI's *NEC-WIRES* software, which takes into account the ground conductivity and dielectric constant beneath the antenna. Compared to *AO*'s output, the results dove into the 15 to 20-dB region, but the F/B was real. With some readjustment of the antenna dimensions and the value of the far-end resistor, the F/B increased to more than 30 dB—that from a piece of wire between two ground stakes! What could be simpler?

A Beverage It Ain't

This antenna (Figure 1) looks amazingly like a Beverage, but its method of operation is entirely different. By analyzing the *RUN* file in *AO*, you can see that for optimized height and length, a phase shift of about 45° occurs between

the center of wire 1 and the center of wire 3.

Taking into account the 180° phase shift caused by the direction of the currents in wires 1 and 3, the total phase shift is about 135°, with wire 3 leading (a reflector). From this, you can see that the Ewe receiving antenna is essentially a two-element driven array in which the rear element (wire 3) is fed via the top wire (wire 2). Wire 3 has about 65% as much current as wire 1. Figure 2 shows the azimuth and elevation patterns of a single 80-meter Ewe over average ground. Because part of the antenna is horizontal, I was concerned about noise pickup degrading the overall results. The horizontal gain computed to be about 20 dB lower than the vertical gain, and at a high angle off the side.

One surprise is that the F/B holds over several megahertz. That led me to design a second antenna covering 1.8 to 4.0 MHz. The calculated F/B is greater than 25 dB over this entire range without adjustment. This design will be shown later.

Feeding and Terminating the Ewe

Figures 3 and 4 show two ways of feeding the Ewe. The basic feed impedance is about 450 Ω, so a transformer with a turns ratio of 3:1 provides a good match. The value of the terminating resistor varies according to the wire height, wire length and band of operation, and whether bottom feed or top feed is used. I devised the top-feed system so that the RG-58A coax could be run overhead. Because I considered a wire 10 feet high something that could be managed easily by most amateurs, I used *NEC-WIRES* to generate Tables 1 through 4 using a 10-foot height as one parameter.

Reversible Ewe for 80 Meters

In order to experiment with this antenna, the first one built had identical 3:1 turns ratio ferrite transformers (50 to 450 Ω) at both ends of the Ewe. Two RG-58A coax cables ran to the shack so that the feed and the termination were at the receiver. This allowed nulling real signals and noise arriving by skywave to determine the antenna's effectiveness. I quickly discovered that a high F/B could not be obtained with a purely resistive termination, so my old Beverage control box was pressed into service. This control box has an adjustable RLC termination, which was just what I needed. Results on nulling skywave signals ranged from minimal to as high as 40 dB. This is as expected, since only stations directly off the back are in the pattern null. The termination consists of a 500-pF air-dielectric variable capacitor, a 4.7-μH inductor (a low-Q inductor is adequate), and a 100-Ω potentiometer, all in series.

160 and 80-Meter Design

As mentioned before, a compromise design was made to cover 1.8 to 4 MHz. The optimum dimensions are shown in Figure 5. Gain at 1.8 MHz calculated as -22 dBi and at 4 MHz, -12.3 dBi.

Two-In-Line Array

Next, I investigated an array of two Ewe antennas. When two elements are fed as an endfire array, the forward beamwidth remains the same, but the pattern off the back improves. Figure 6 shows the in-line physical configuration that gives excellent results on 80 meters. Feeding both antennas with equal currents and 135° phasing provides the patterns shown in Figures 7A and 7B.

Two-in-Broadside Array

Two Ewe elements, side by side, can be fed in phase to produce a beam that is much narrower in azimuth. Element spacing should not exceed $5/8 \lambda$ (about 162 feet at 3.8 MHz). Figure 8 shows the physical configuration used, and Figure 9 shows how the pattern varies with element separation. Use equal-length feed lines run to a common central point, beyond which the lines can be placed in parallel.

Construction

Little needs to be said about how to build this antenna. Height and length are not critical and small ropes or cords can be used to pull up the top wire. I stretched my experimental antenna from the corner of my house to a convenient

wooden pole. Of course, trees or towers will do fine as supports. I recommend that the upright wires be not closer than 10 feet to a tall metal tower and that the antenna not receive in the direction of a supporting tower.

For the ground rods, I used 2-foot, 8-inch pieces of copper-plated steel, made by cutting 8-foot ground rods into three pieces, but common pipe will work. The small ferrite transformer and the potentiometer are mounted in small diecast boxes equipped with binding posts on the top. The boxes are clamped to the ground rods using stainless-steel hose clamps. Any type of copper wire can be used for the antenna.

I use a pair of 11-dB low-noise amplifiers to bring signal levels up to levels comparable to those provided by full-size antennas.

Summary

Antennas much simpler than this—that play as well as this—are hard to come by. Give a Ewe a try. I'm sure you'll find it improves ewer receiving capability on the low bands!

(1) Floyd Koontz, WA2WVL, "A High-Directivity Receiving Antenna for 3.8 MHz," QST, Aug 1993, pp 31-34.

See Feedback in April QST.

Figures

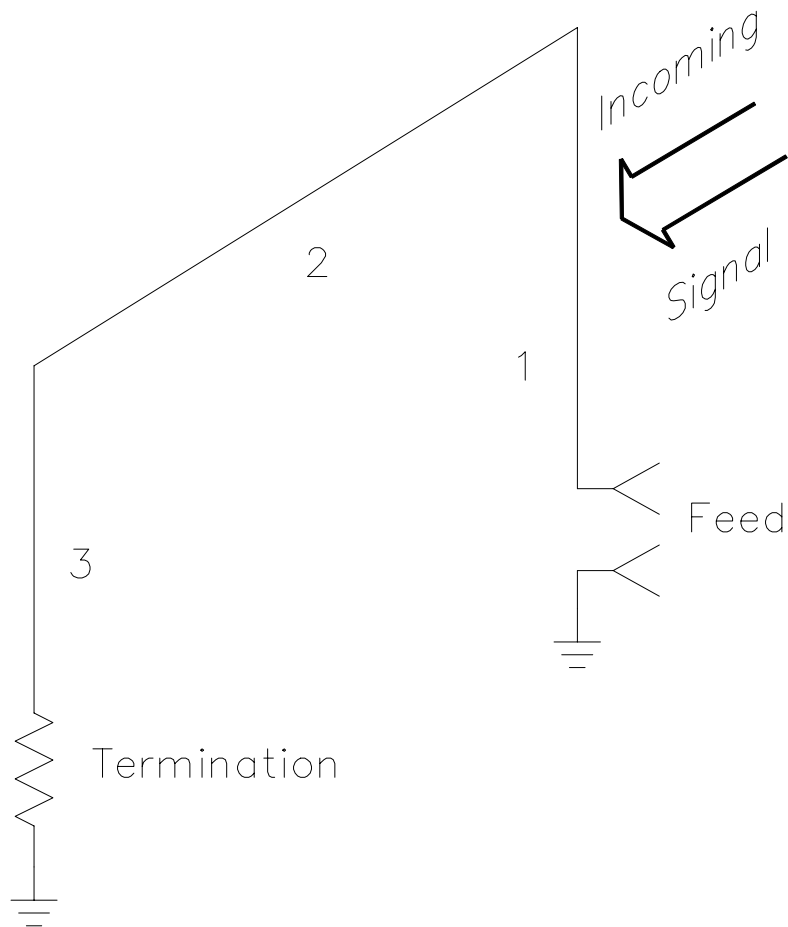

Figure 1—The Ewe is the receiving antenna. The antenna end attached to the resistor is the rear. The antenna produces

a cardioid pattern.

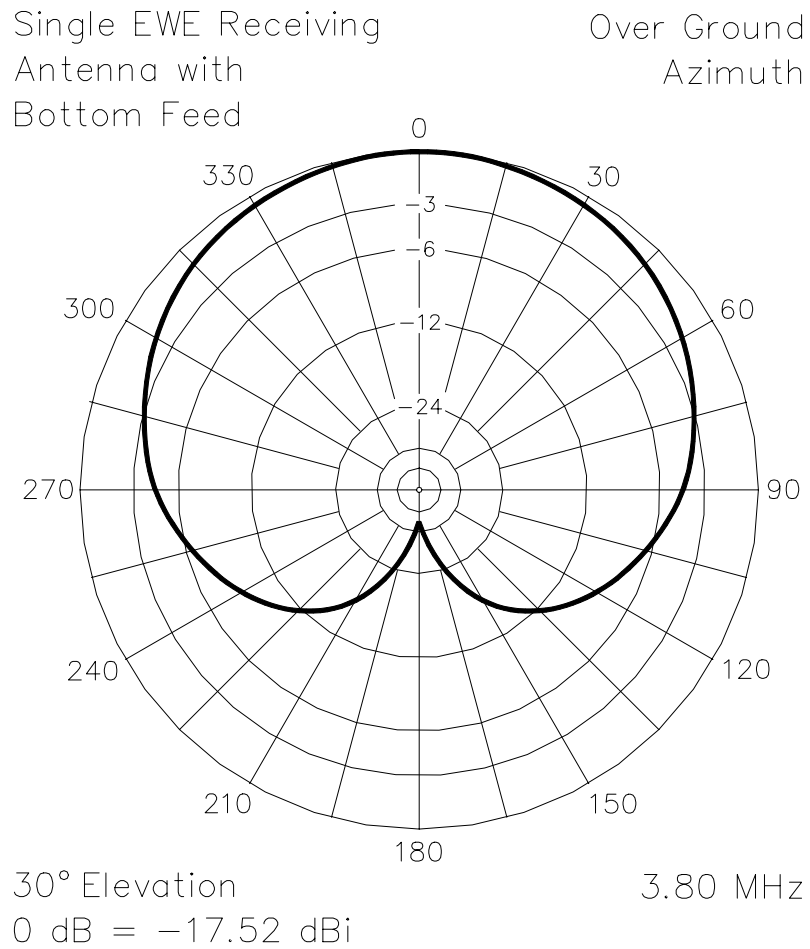
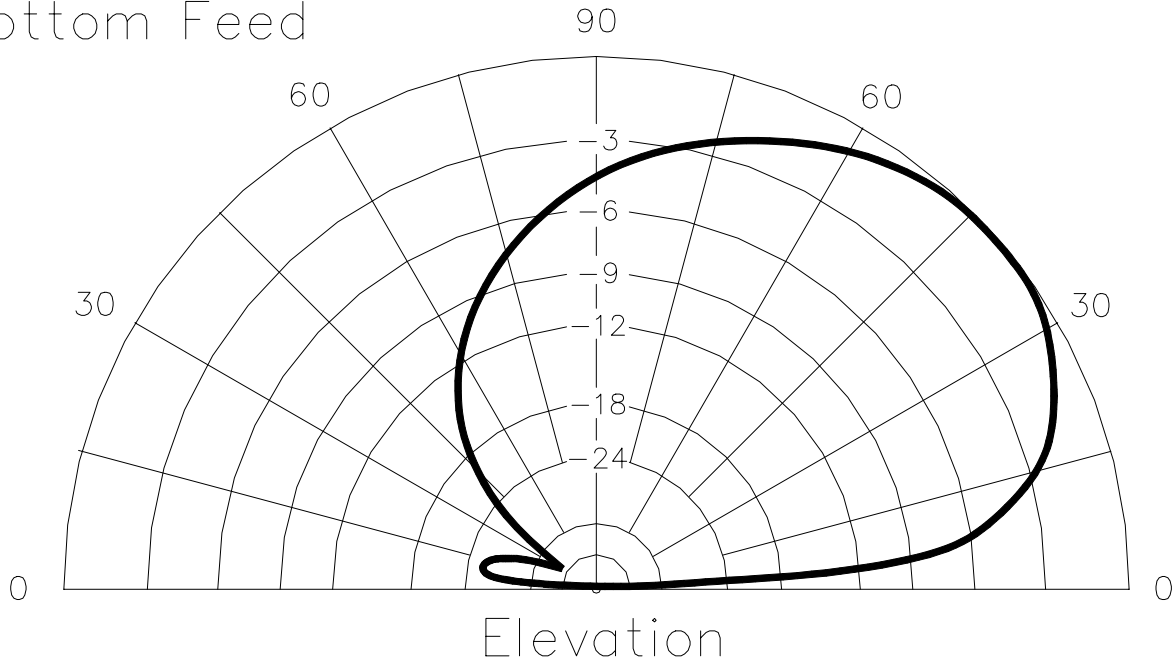

Figure 2A—Azimuth pattern of a single Ewe over average ground.

Single EWE Receiving
Antenna with
Bottom Feed

Over Ground



0 dB = -17.42 dBi

3.80 MHz

Figure 2B—Elevation pattern of a single Ewe over average ground.

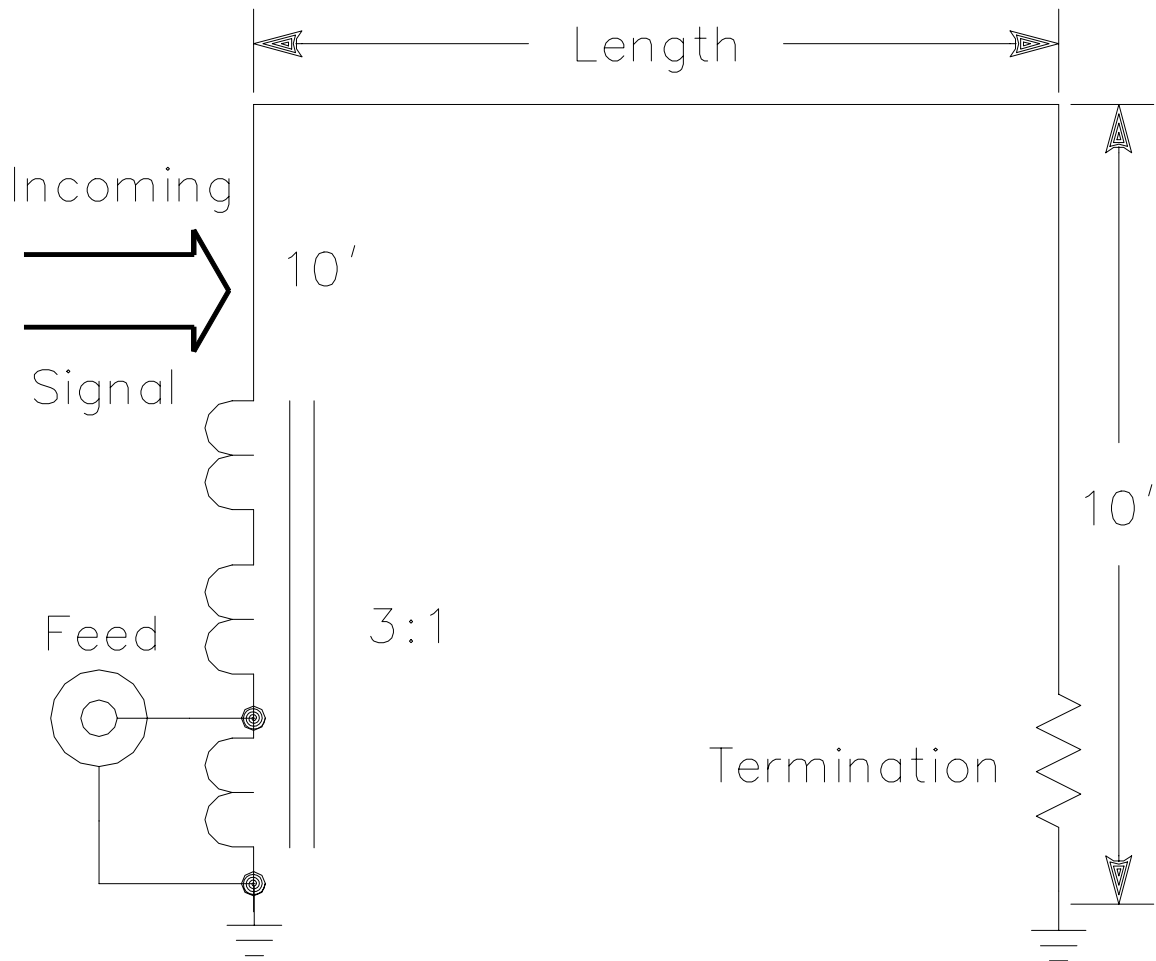

Figure 3—A 10-foot-high bottom-fed Ewe with a 3:1 impedance-matching transformer and a resistive termination.

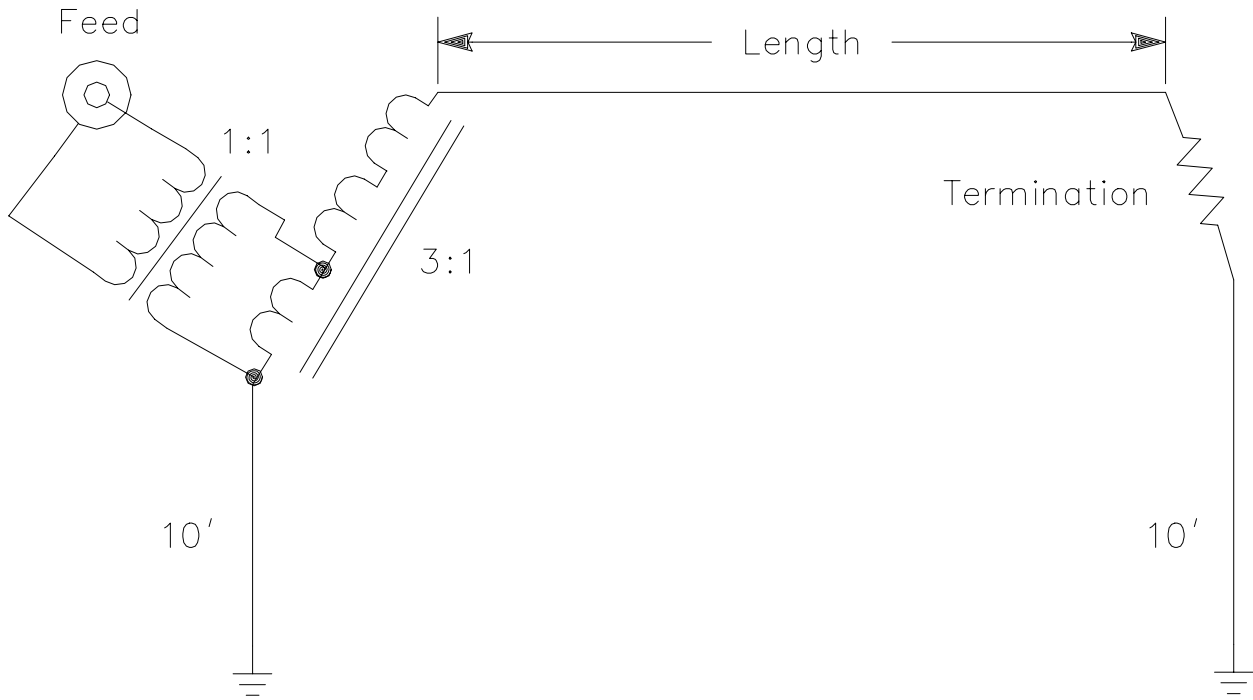

Figure 4—A top-fed, 10-foot-high Ewe with a 3:1 impedance-matching transformer and a resistive termination.

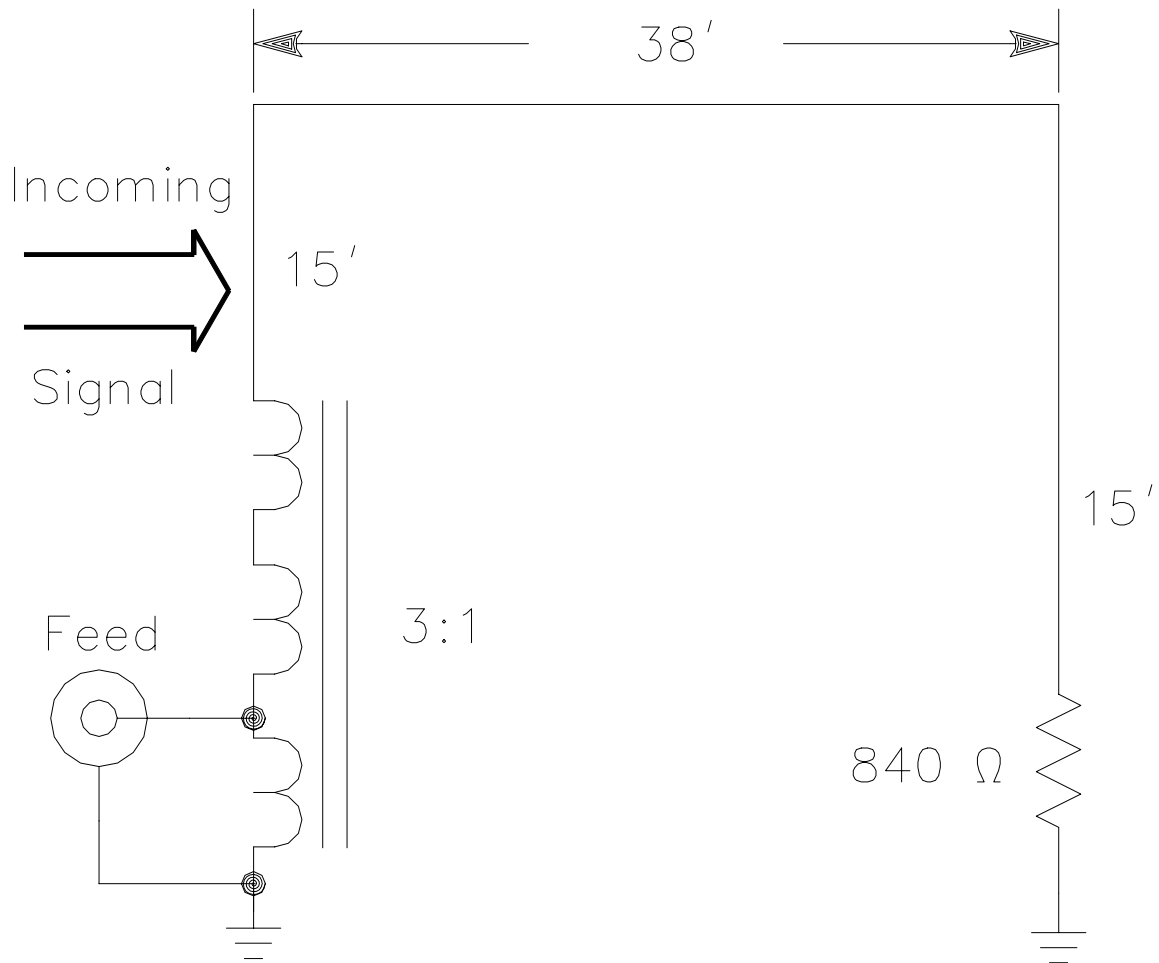

Figure 5—An 160/80-meter Ewe 15 feet high.

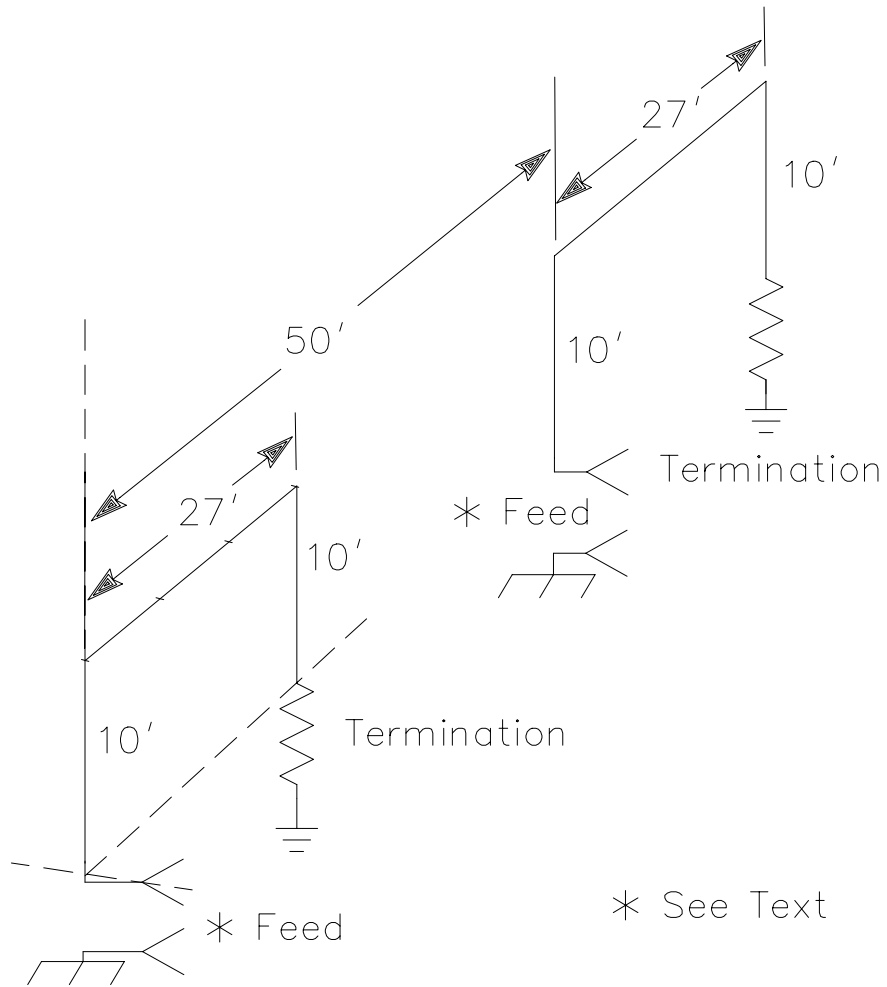

Figure 6—An array of two 10-foot-high Ewes.

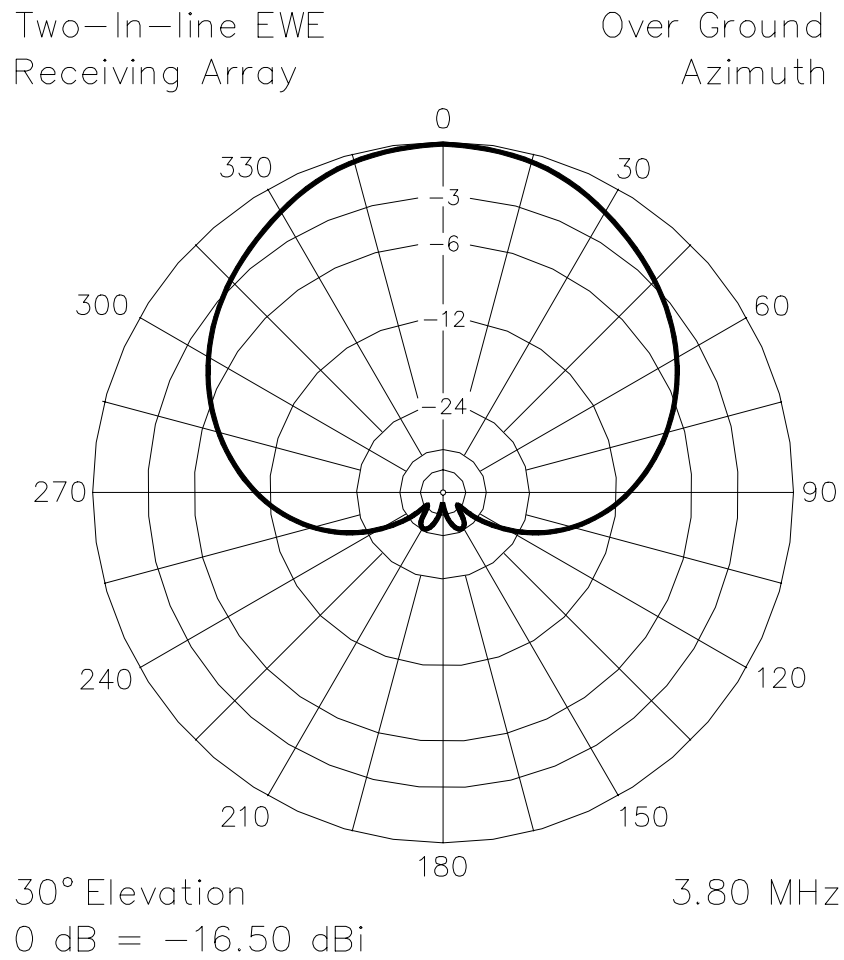
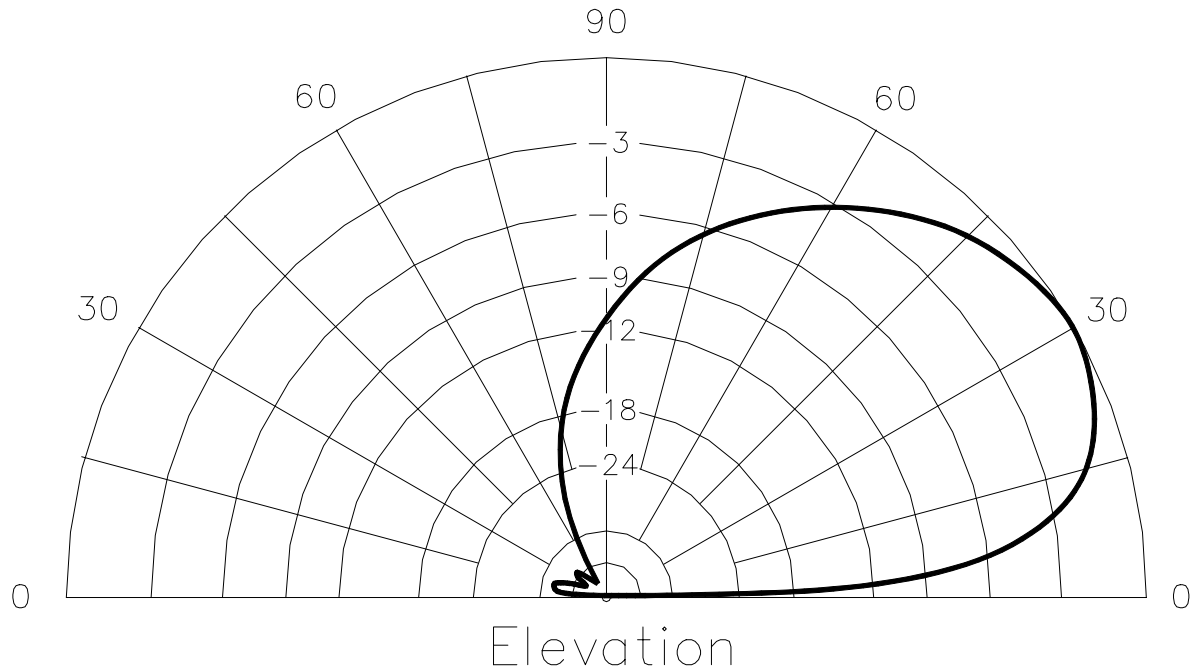

Figure 7A—Azimuth pattern of the dual-Ewe array of Figure 6.

Two-In-line EWE
Receiving Array

Over Ground



0 dB = -16.50 dBi

3.80 MHz

Figure 7B—Elevation pattern of the dual-Ewe array of Figure 6.

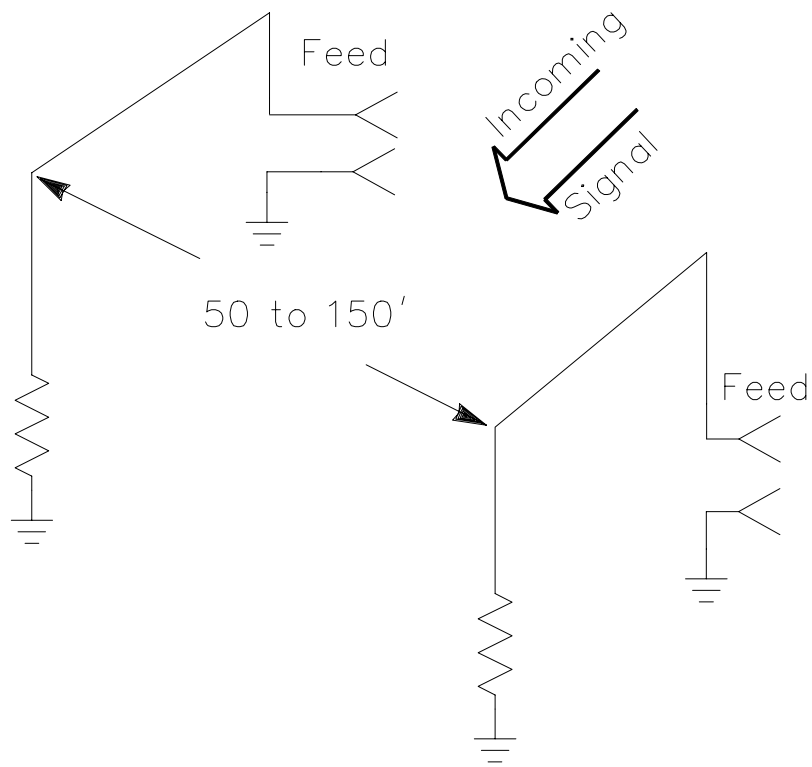

Figure 8—A pair of side-by-side Ewes fed in phase to produce a narrower azimuth pattern (see Figure 9).

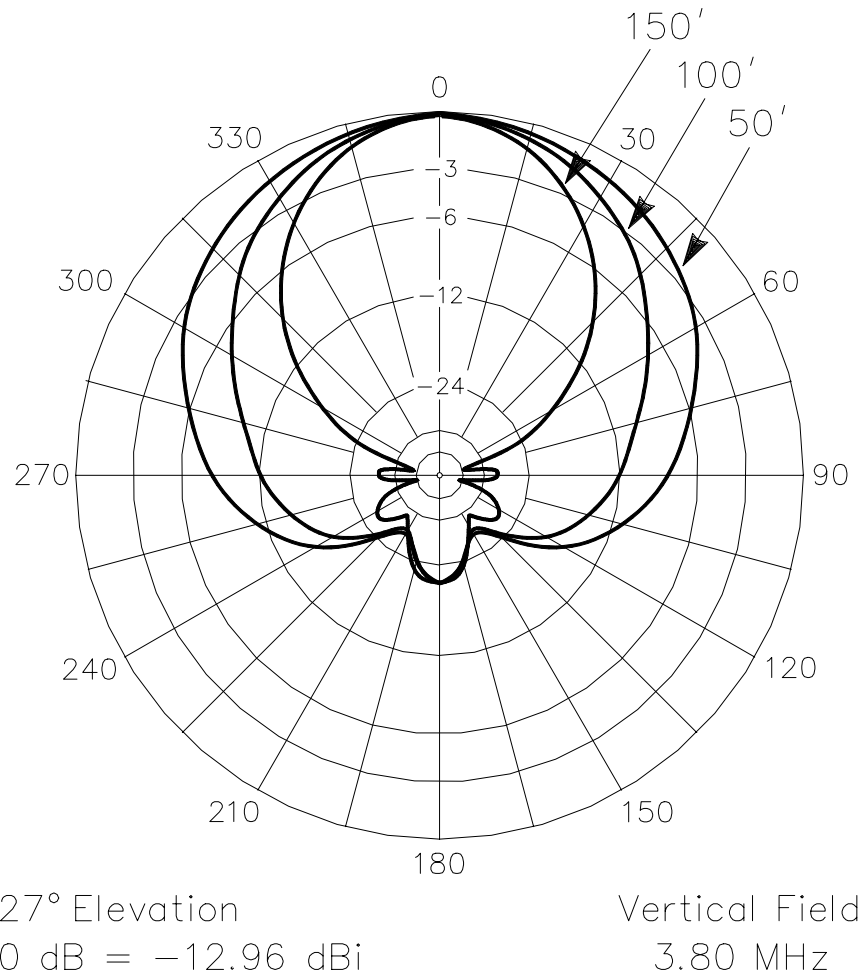

Figure 9—Azimuth patterns of the Figure 8 array for varying degrees of antenna separation.

Table 1

Ewe Parameters for Bottom Feed at 3.8 MHz, with an Antenna Height of 10 Feet and Elevation Angle of 30°

<i>Ant. Length (feet)</i>	<i>F/B (dB)</i>	<i>Gain (dBi)</i>	<i>Termination (Ω)</i>
15	17.9	-21.4	650
20	23.5	-19.5	740
25	34.8	-18.0	850
30	27.0	-16.9	870
35	20.1	-15.9	900

Table 2

Ewe Parameters for Bottom Feed at 1.8 MHz, with an Antenna Height of 10 Feet and Elevation Angle of 30°

<i>Ant. Length (feet)</i>	<i>F/B (dB)</i>	<i>Gain (dBi)</i>	<i>Termination (Ω)</i>

30	23.3	-27.2	1000
40	35.2	-25.1	1060
50	28.6	-23.4	1200
60	18.2	-22.1	1220

Table 3

Ewe Parameters for Top Feed at 3.8 MHz , with an Antenna Height of 10 Feet and Elevation Angle of 30°

<i>Ant. Length (feet)</i>	<i>F/B (dB)</i>	<i>Gain (dBi)</i>	<i>Termination (Ω)</i>
15	15.9	-22.1	825
20	19.3	-20.0	910
25	24.9	-18.3	960
30	40.4	-17.0	970
35	26.6	-16.0	980

Table 4

Ewe Parameters for Bottom Feed at 1.8 MHz, with an Antenna Height of 10 Feet and Elevation Angle of 30°

<i>Ant. Length (feet)</i>	<i>F/B (dB)</i>	<i>Gain (dBi)</i>	<i>Termination (Ω)</i>
30	20.3	-27.5	1150
40	29.8	-25.1	1230
50	30.3	-23.4	1290
60	20.8	-22.0	1300

April 1995 QST Volume 79, Number 4

Feedback

♦ Please refer to “Is this Ewe for You?”, *QST*, Feb 1995, page 32, Table 4. The heading for that table should read: “Ewe Parameters for Top Feed...” instead of “Bottom Feed.”—*tnx Floyd Koontz, WA2WVL*