

SHORTWAVE BULLETIN

Issue no. 1792, March 2, 2014.

Deadline e-mail next issue: 0900 UTC, March 16, 2014.

Vasaloppet har precis avslutats och det väldigt spännade på slutet. Som alltid gäller att disponera krafterna rätt. Men man blir lika förvånad alltid av långlopp oavsett idrottsgren. Så många som ligger inom någon minut från segraren efter så lång sträcka. Fantastiska prestationer.

Har hållit på med dataövningar den senaste veckan så det har inte blivit så mycket bevänt med lyssning. Mer om detta längre fram.

Trots mycket dåliga konds så är en del trots allt ganska aktiva på kortvåg fortfarande. Loggen blir ju ganska lång i varje nummere. Naturligtvis är det ofta samma stationer som kommer igen från nummer till nummer.

Men en hel del trevliga saker dyker ändå upp. Bjarne Mjelde och Odd Jörgen Sagdahl har varit i Kenya. Kolla deras Kilimanjaro-logg. Jesper, grabben våran, reser omkring i Sydamerika och tar mig friheten att klippa in från hans rapport till hemmet. Fina upplevelser!

Keep on

=====

R e d a k t i o n:

Thomas Nilsson
Mardalsv. 372
262 93 Ängelholm

Tel: 0431-27054

E-mail:
thomas.nilsson@ektv.nu

SWB-info

SWB online på HCDX:

SWB member information:

SWB anniversary issue:

Dateline Bogotá 1993-1998:

SWB latest issue:

<http://www.hard-core-dx.com/swb>

<http://www.hard-core-dx.com/swb/member.htm>

http://www.hard-core-dx.com/swb/SWB_history.pdf

<http://www.hard-core-dx.com/swb/Dateline.htm>

<http://www.thomasn.sverige.net/password.htm>

QSL, kommentarer, mm.

Christoph Ratzer: One beautiful „QSL“ today: Itanagar 4990 after one week: (via itanagar@air.org.in)

Sir,

The reception of our SW Transmitter on Date: 11.February 2014, Time: 0549 - IST = 0019 - UTC time, is checked in consultation with my colleague of Programme wing of this station through audio file sent by you and it is to be confirmed that you have correctly monitored AIR, Itanagar.

Thank you for monitoring and sending the reception report.

Rajesh Chandra,

Deputy Director (Engineering)

All India Radio, Itanagar

Many reports since the last years, but now I have it. And the next reports are Golmud and Gangtok, than I have all Himalayan transmitters complete: Azad Kashmir, Srinagar, Leh, Shimla, Nepal, Bhutan, Lhasa, Qinghai, Imphal, Itanagar...

Christer Brunström: Radio Kuwait 15540 kHz svarade med brev och programschema. Av brevet framgår att programschemat är bekräftelsen på min rapport. Ett minst sagt egendomligt arrangemang. WRMI, Okeechobee, Florida 17790 kHz trevligt QSL-kort. V/s Jeff White.

Giampiero Bernardini: Ciao Thomas, I was in Bocca di Magra (La Spezia, Liguria, Italy) with Dario Monferini for our DXnights, BOC 32 edition. Here you can find some tips, maybe you can use some for your great SWB.

John Ekwall: Dåliga konds speciellt de senaste dagarna så jag har inget att rapportera till SWB.

(Tack för skannade kopior på gamla QSL, dessa kommer i nästa nummer! /TN)

Björn Fransson: Hoppsan! Jag ska bidra med ett QSL och ett tips! Det var inte precis igår. Kanske blev jag lite entusiastmerad av Nostalgitrippen på Ålands Hav tillsammans med DX-Alliansens Vänner?

QSL: LKB/LLE-5895 via Bergen Kringkaster (50 W) med snyggt litet kort per post och dessutom via e-mail.

Dan Olsson: Här kommer ett bidrag signerat DO. Så mycket lyssning har det inte blivit med lite ju att redovisa. Tyvärr lyckades jag förra helgen klippa i sönder min antenn så den numera bara är 7 meter lång och ligger på marken ut i trädgården.

QSL har det också inkommit: **5780 Horizon FM** e-brev, **6190 China Buisness**

Radio/Golmud kort, **6285 R Verona** e-brev o kort, **6300 States of Unrest** e-brev o kort samt **6308 R Mir** e-brev o kort. Trots avklipp antenn så har jag hört lite grann.

Anker Petersen: First of all, thank you to Dario Monferini for excellent tips from BOC-32! Here are my latest loggings from Skovlunde on the good old AOR AR7030PLUS with 28 metres of longwire.

2325	Feb23	2005	VL8T Tennant Creek, Australia, reports, interview, fair (BOC 32 Monferini & Bernardini)
2485	Feb23	2008	VL8K Khaterine, Australia, interview, fair (BOC 32 Monferini & Bernardini)
3200	Feb15	1921	R. Transmundial, Mpangela Ranch, inglês, rubrica de música pop'; 35332. Carlos Gonçalves
3210	Feb18	1300	"Vintage FM The music you've grew up with" observed from 13:00, 1950s-60s rock. Reasonably loud in Sydney / Aust. in English. http://vintagefm.com.au/ TX site located 90 km south-west of Sydney city. Not heard before. License OK in ACMA database. In addition: 1KW into vertical, callsign: AXA225 Nick Hacko VK2DX ----- Very interesting Nick! Today was a rare morning for me, as I did not check 3210 or 5050, as I was busy with other stations. These frequencies formerly were used by Craig Allen's station "Ozy Radio," which is expected to be reactivated. (Ron Howard, San Francisco)
3210	Feb24		Vintage FM relay, random checking 1330 to 1515, Feb 24 and 25 found totally unusable, open carrier, below threshold level; what a difference from my decent Feb 23 reception (Ron Howard, Asilomar State Beach, CA, USA)
3310	Feb14	2311	R. Mosoj Chaski, Cochabamba, quíchua, texto; 33442, QRM adj. de emissora ponto a ponto. Carlos Gonçalves
3344,900	Feb18	1316	Either Indonesian or PNG. Very weak. Nick Hacko VK2DX
3365	Feb20	1950	Radio Milne Bay, Alotau, SIO 242 Christoph Ratzer
3905	Feb20	1905	Radio New Ireland, Kavieng, Papua, SIO 252 Christoph Ratzer
3977,40	Feb15	1319	UNID. RE: DXLD 14-06: "3977.40 on Feb 1, tuned in at 1359 to hear a weak station here with YL talking, but too weak to guess at the language; 1401 EZL music till off at 1402*. RRI Pontianak years ago was often heard on about 3976.03v, a rather unique frequency. Today was surprised not to hear the often present KCBS Pyongyang which drifts around this vicinity with terrible audio, but no hint of that today. Needs more monitoring. Due to the off frequency, perhaps a slight chance it was RRI Pontianak? [NO]". My UNID has been IDed by the expert assistance of Mauno Ritola (Finland), as Echo of Unification (KOREA NORTH) and found // 6250. On Feb 15 at 1319, for the first time I was hearing Korean and patriotic music, but did not know who it was, until Mauno IDed. Continues to drift around wildly; having to constantly re-tune as it quickly goes up and down in frequency. This is above the KCBS blob on about 3973.40, but really hard to tell as it is such a mess, audio wise. Thanks to Mauno for clearing up my mystery for me! (Ron Howard, San Francisco at Ocean Beach, CA, USA)
4660	Feb20		AIR Leh is not heard on 4660 when I checked last night and today. Maybe they have gone back to 4760? Sign off is at 1630 UTC. (Yours sincerely, Jose Jacob, VU2JOS National Institute of Amateur Radio Hyderabad, India www.qsl.net/vu2jos) ----- QSL pause, (73 wb) Eher Wetterschicht. In Leh hat es dieser Tage um minus 20 Grad, und wer die Situation dort im Himalaya kennt wundert sich nicht wenn dann der Sender einige Tage nicht geht. Dann kann Der Stationsdirektor mal seine Wimpel ordnen und die „QSL-Post“ erledigen. (73 Christoph Ratzer) ----- Ja, ja. Indien und seine Verwaltung! Da gibt es ja schöne Fotos zu bestaunen! Hier einige Impressionen vom AIR QSL-Desk: http://mirjamvantilburg.files.wordpress.com/2011/04/jan2bbanning2bbureaucracy.jpg http://www.12thpress.com/assets/images/uploads/2008/03/bureaucrats.jpg http://www.mdf-berlin.de/archives/www.mdf-berlin.de/typo3temp/pics/ff8030d68b.jpg (Tschüß, Martin Elbe, via A-DX)
4716,7	Feb13	2328	R. Yatun Ayllu Yura, Yura, quíchua ou aimara, música pop' índia; 35332. Carlos Gonçalves
4747,2	Feb13	2325	R. Huanta 2000, Huanta, castelhano, texto, informações várias; 35332. Carlos Gonçalves
4749,95	Feb18	1240	Certainly sounded like the start of the KGI program, but cannot say that I heard a program ID; again with bits and pieces of English; not doing well against Bangladesh and possibly two Chinese stations. Rather a mess and certainly tough to dig out the English. Seemed to be a half hour show till about 1313. Still needs more work. Ron Howard
4750	Feb15	1701	Bangladesh Betar, Kahbirpur, bengali, noticiário; 35432, sinal em perda acelerada, áudio ausente cerca das 1706. Carlos Gonçalves
4750,00	Feb19	2250	Voice of China, Hailar Chinese discussion, Russian QRM in USB 33243 // 4800 (55344) AP-DNK

4755	Feb7	1133	<i>UNID. RE: DXLD 14-07: "4755. Signal here at 1133. Very weak and not strong enough for audio. Too late for Brazil. Finally went off at 1159:31. Never did get any audio. (7 Feb.)</i> ----- Again observed this signal to about 1159:35 sign off. Very very poor conditions today and was only able to "see" the signal. (8 Feb.) 73 (Dave Valko, Dunlo, PA, USA, Hard-Core-DX mailing list via DXLD) ----- Surely PMA The Cross, at its typical cutoff time. Dave is being very cautious. But why didn't he measure this to two or three decimal places? Characteristically around 4755.55v which would surely make it even less unidentified (Glenn Hauser, DXLD)" ----- Glenn had no way of knowing, but Dave actually was hearing an UNID on 4755.00, not the Cross. I checked on Feb 10 for Dave and the Cross went off immediately after DTMF tones at 1157:01* on about 4755.53. Dave's UNID was going off about two minutes after that, so his UNID could not have been a spur from the Cross. Dave has a good screenshot showing the two different frequencies and different sign off times. I was not able to hear anything on 4755.00 after the Cross went off. A mystery! (Ron Howard, San Francisco at Ocean Beach, CA, USA)
4760	Feb13	2228	ELWA, Monróvia, canções; 45433. Carlos Gonçalves
4765	Feb24	0210	Radio Progreso, Cuba, songs, "el numero uno", then Cuban news, fair, over Tajikistan (BOC 32 Monferini & Bernardini)
4774,9	Feb13	2321	R. Tarma, Tarma, castelhano, anúncios comerciais, noticiário desportivo; 45444 (!).Carlos Gonçalves
4774,93	Feb19	2310	R. Tarma, Tarma Spanish talk 25222 AP-DNK
4775	Feb14	2217	R. Congonhas, Congonhas MG, canções, ID apenas como "R.Congonhas AM"; 24432, QRM do PRU. Carlos Gonçalves
4780	Feb22	1804	RTV Djibouti, HOA songs, weak fair (BOC 32 Monferini & Bernardini)
4785	Feb15	2239	R. Caiari, Pt.º Velho RO, canções, texto; 25332. Carlos Gonçalves
4789,8	Feb14	2335	R. Visión, Chiclayo, castelhano, canções, texto; 34433, modulação débil, QRM adjacente. Carlos Gonçalves
4805	Feb13	2228	R. Dif. ^a do Amazonas, Manaus AM, informações, anúncios comerciais, canções; 44433, QRM adj. da CHN, em 4800. Carlos Gonçalves
4810	Feb24	1904	Armenian National R., Yerevan, Arabic prg, fair-good (BOC 32 Monferini & Bernardini)
4815	Feb14	2333	R. Dif. ^a , Londrina PR, canções; 35433. Carlos Gonçalves
4820.53	Feb22	0020	Kyrgyz R1, Krasnaya Rechka, Bishkek Kyrgyz talk with musical interludes - still here ex 4795, QRM Xizang 4820 22222 // 4010 (45343) AP-DNK
4830	Feb23	0037	Mongolian R. 1, Altay, talks, weak (BOC 32 Monferini & Bernardini)
4835	Feb14	1339	VL8A Alice Springs NT. Live coverage of cricket match between Australia and So. Africa; poor-fair (Ron Howard, San Francisco at Ocean Beach, CA, USA)
4835	Feb14	1938	VL8A, Alice Springs, Territ.º do Norte, inglês, notícias, info. meteorológica, música pop'; 25432. Carlos Gonçalves
4835	Feb22	1820	VL8A Alice Springs, Australia, reports, English, weak. Very good the day after (BOC 32 Monferini & Bernardini)
4845	Feb13	2242	R. Cultura Ondas Tropicais, Manaus AM, noticiário, canções e música latino-americana; 44443, QRM de CODAR. Carlos Gonçalves
4865	Feb14	2331	R. Verdes Florestas, Cruz.º do Sul AC, leitura do terço; 33442, QRM de CODAR. Carlos Gonçalves
4865,7	Feb14	2210	R. Alvorada, Londrina PR, texto; 23431, QRM de CODAR. Carlos Gonçalves
4875,1	Feb13	2244	R. Dif. ^a de Roraima, Boa Vista RR, canções; 44443, QRM de CODAR. Carlos Gonçalves
4894,96	Feb16	2320	R. Novo Tempo, Cp.º Grande MS, propag. relig, canções a condizer; 24331, QRM de CODAR. Carlos Gonçalves
4895,00	Feb19	2305	Mongoliin R, Murun Mongolian talk, music and songs 25222 Was off the air 09.02, but now back, but 4830 Altay not heard AP-DNK
4905	Feb16	2322	Nova R.Relógio, Rio de Jan.º RJ, propag. relig.; 23431, QRM da CHN. Carlos Gonçalves
4910	Feb22	2130	VL8T Tennant Kreek, reports, fair //4835 //5025 (BOC 32 Monferini & Bernardini)
4910	Feb23	0041	AIR Jaipur, India, Indian songs, fair (BOC 32 Monferini & Bernardini)
4914,9	Feb15	2242	R. Dif. ^a de Macapá, Macapá AP, futebol; 25331. Carlos Gonçalves
4914,97	Feb19	2325	R. Daqui, Goiânia, GO (presumed) Portuguese hymns and orchestra music 24232 Heterodyne presumed from R Dif. Macapa on 4915.00 AP-DNK
4925,2	Feb13	2247	R. Educação Rural, Tefé AM, 13/2, A Voz do Brasil, s/ áudio entre as 2250 e as 2254, info. horária, ID e anúncio das freqs., às 2300, segundio-se progr. de propag. relig.; 45433. Carlos Gonçalves
4940	Feb16	1500	Voice of Strait with Focus on China. This program in English was preempted during the Spring Festival (Lunar New Year's celebrations), but is back to normal scheduling now;

			fair with nice IDs between each news item; "You are now listening to Focus on China in Voice of Strait broadcast station."
4940	Feb13	2249	R. San Antonio, Villa Atalaya, castelhano, propag. relig., alguma música; 35332. Carlos Gonçalves
4949,76	Feb13	1930	RNA-Canal "A", Mulenvos, fim do noticiário, c/ resumo dos principais pontos, seguindo-se rubrica do canal Rádio 5, p/ o Jornal Desportivo; 44433, QRM adj. de estação ponto a ponto. Carlos Gonçalves
4955	Feb13	2319	R. Cultural Amauta, Huanta, quíchua, texto; 45333. Carlos Gonçalves
4965	Feb14	2213	R. Alvorada, Parintins AM, A Voz do Brasil, 1.ª parte; 34433, QRM adj. de emissora ponto a ponto. Carlos Gonçalves
4975	Feb14	2323	R. Iguatemi (?), Osasco SP, canções; 13431, QRM de estação ponto a ponto. Carlos Gonçalves
4976	Feb14	1932	R. Uganda, Kampala, inglês, música, rubrica acerca de educação; 45332. Carlos Gonçalves
4990	Feb16	2326	R. Apintie (p), Paramaribo, texto, música; 14421. Carlos Gonçalves
5005	Feb14	1935	RNGE, Bata, castelhano, canções em castelhano; 45433. Carlos Gonçalves
5005	Feb22	2135	Radio Bata, Guinea E., news in Spanish, weak/fair (BOC 32 Monferini & Bernardini)
5010	Feb22	*2138	Radio Taiwan Int. start with Chinese slow songs, id Ch 2142 Taipei, good (BOC 32 Monferini & Bernardini)
5025		2132	VL8K Katherine, Australia, reports, //4910 good (BOC 32 Monferini & Bernardini)
5035	Feb14	2141	R. Aparecida, Aparecida SP, A Voz do Brasil, seguindo-se o progr. Com a Mãe Aparecida, às 2202; 45433. Carlos Gonçalves
5035	Feb14	2201	R. Educação Rural, Coari AM, retransmissão do progr. Com a Mãe Aparecida, da R. Aparecida; cerca de 1" de atraso no áudio; 23431. Carlos Gonçalves
5050,00	Feb19	2335	Beibu Bay R, Nanning Chinese ann, Chinese pop songs 35233 AP-DNK
5066,3	Feb14	1936	R. Télé Candip, Buina, francês, notícias locais, canções afric. e, após as 2000, música pop' afric.; 25432. O fecho da emissão terá ocorrido escassos minutos após as oito e seis. Carlos Gonçalves
5730	Feb25	-0349*	Yet another new frequency of 5730, "radio station YHWH" (religious pirate), 0302-0349*, Feb 25 (Tuesday UT). Yesterday's ex 5785! Usual anti-Catholic, Christian, gay, etc. presentation with reading from a "53 page document" along with his comments; occasional IDs; this is about the third time I have heard this particular program; usual sign off format. Strange that he never IDs just what the "53 page document" is or who wrote it or if there is an organized religion that represents his views. Audio at https://app.box.com/s/2bgcmi7yupqrtonc5rcz (Ron Howard, Asilomar State Beach, CA)
5780,01	Feb16	2150	Atlantis FM, Tenerife English ann, pop songs for tourists, 2200 ID, news, adv, 2203 pop songs 35243 // live streaming on www.atlantis.fm AP-DNK
5780,01	Feb23	1730	Horizon FM, Tenerife English ann, British pop songs // live stream www.horizon.fm which was 36 seconds behind SW 35333 AP-DNK
5785	Feb24	0204	Feb 24 (Monday UT) heard "radio station YHWH" on new frequency 5785 at 0204. Usual format of reading from some document and commenting on it; sounded like a repeat of an earlier show; 0232 usual music/song before sign off; "Thank you so much for tuning into station YHWH. Goodbye and I love you. Until next time. Station YHWH now signing off the air." He never stays on the same frequency for very long. Ron Howard
5857,5	Feb16	1316	HLL2 Seoul. Heard with good signal strength in AM + USB + LSB, but very garbled audio with weather information in English; in the clear till Voice of Jinling sign on at 1231 on 5860 (Ron Howard, San Francisco at Ocean Beach, CA, USA)
5860	Feb15	-1506*	Voice of Jinling. <i>RE: DXLD 14-06: "New schedule of Voice of Jinling in Chinese from Jan. 20: 1230-1600 on 5860 NJG 100 kW / 161 deg to EaAs, ex 1430-1700 Stable signal in Sofia on Jan. 30 around 1530 till s/off at 1600. (Bulgarian DX blog via Ivo Ivanov, DXLD)</i> ----- Hi Ivo, Believe we will need to wait until the end of the Spring Festival (Lunar New Year's celebrations) to know for sure just what the Voice of Jinling (VOJ) schedule currently is. Until after Feb 14, probably all stations will be back to normal, but I believe now many Chinese stations are having special programs and unique scheduling . . ." I was correct about the extended/erratic schedule being only during the Spring Festival (Lunar New Year's celebrations). Checked Feb 16 to find the usual double sign on; false start at *1231*; on for 8 seconds and off for 32 seconds and then the real start at *1231; IDs with "FM" reference; sign off at 1504:41*. Feb 15 sign off about 2 minutes later than that. So back to normal now and conforming to Aoki's info (Ron Howard, San Francisco at Ocean Beach, CA, USA)
5910	Feb13	2305	Alcaraván R via A Voz da tua Consciência, Lomalinda, castelhano, propag. relig.; 45433. Carlos Gonçalves
5910,07	Feb23	0020	Alcaravan Radio, Colombia, nice romantic songs, fair (BOC 32 Monferini & Bernardini)
5915	Feb16	1931	ZNBC-Radio 1, Lusaka, dialecto local, canções africanas; 45433. Carlos Gonçalves

5939,8	Feb13	2307	R. Voz Missionária, Camboriú SC, propag. relig.; 45433; // 9664 c/ pior desempenho, acrescido de QRM. Carlos Gonçalves
5939,8	Feb22	2220	Voz Missionaria, Camboriù, Brazil, religious, fair (BOC 32 Monferini & Bernardini)
5952,43	Feb26	-0227*	Radio Pio Doce. Off with the unique and easy to ID, even with a weak signal, distinctive whistling "Colonel Bogey March" (commonly known as the River Kwai March), along with ID followed by chimes. (Ron Howard, Asilomar State Beach, CA, USA)
5964,69	Feb15	1609	Radio Klasik after being on exact frequency with more power for several days, they have started broadcasting again with weaker, off frequency tx. Heard with only "Radio Klasik" IDs and playing pop songs (Ron Howard, San Francisco at Ocean Beach, CA, USA)
5965,0	Feb18	2110	At 2110 UT Febr 18 heard both on air: rather even frequency 5965.0 kHz of VoIRIB service in Japanese language, hit heavily by MLA RTM Klassik Nasional FM on odd signal 300 Hz away lower side on exact footprint 5964.705 kHz. vy73 wb
5970	Feb14	2138	R. Itatiaia, Belo Horizonte MG, A Voz do Brasil; 43432, QRM adjacente. Carlos Gonçalves
5980	Feb13	2303	R. Chaski, Cuzco, castelhano, propag. relig.; 34332, QRM adjacente. Carlos Gonçalves
5980	Mar1	1630	Scandinavian Weekend R, Virrat Finnish ann, English pop songs, heavy sideband QRM 33322 AP-DNK
5985,00	Feb24	1250	Myanmar Radio, 1250 through random subsequent checking till 1517. Slightly better reception with the newer tx than the older off frequency tx (Ron Howard, Asilomar State Beach, CA, USA)
5985,84	Feb23	0026	Padauk Myay R., Myanmar, music, weak (BOC 32 Monferini & Bernardini)
5995	Feb15	2309	R. Mali, Kati, francês, rubrica de música pop' africana; 55433. Carlos Gonçalves
6000-	Feb28	0059	music and lite het in the absence of RHC; Portuguese announcement as ``10 horas, Nacional informa``, so I hasten to compare on second receiver 6180 & 11780 RNA --- I think it is, but by 0101, RHC English has cut on 6000. So looks likely to be the Brasília transmitter which is soon to shift to 5990 for DRM tests, as explained in my last report. Certainly need to check 6000 earlier, but RHC can also be on 6000 before 0100 with the irregular `Mesa Redonda` hour, altho apparently with a transmitter change before 0100 English. The third signal on 6000 is probably Turkey from 0100. Het upon 6000 RHC is still audible at 0630 Feb 28 (Glenn Hauser, OK)
6000-	Mar2	0052	No RHC `Mesa Redonda` on this UT Sunday, and no EBC either, altho there is some very weak carrier here. After 0100, when RHC English is starting with IS, no het audible, so EBC off-frequency AM transmitter remains gone, perhaps to 5990 for DRM tests, less likely to be detectable at such low power, and original publicity indicated would be after sunrise, not evenings anyway (Glenn Hauser, OK)
6003	Feb22	1834	Voice of Hope, Korea, slow songs, talks, Korean, fair (BOC 32 Monferini & Bernardini)
6010, 03	Feb14	2139	R. Inconfidência,. Belo Horizonte MG, A Voz do Brasil, anúncio das freqs.+ID, segundo-se-lhe a rubrica Desporto pelo Ar, às 2201; 35433, // 15191. Carlos Gonçalves
6015	Feb24	*0258-	ZBC Radio. A little bit of history here - For many years they always played their distinctive, repetitive xylophone or marimba sounding IS just before 0300, but then in June 2012 they started to instead use an introduction of Spice FM audio feed (pop African songs). Since 2012 has consistently been that musical format that leads up to time pips at 0300. Today was a nice surprise to again hear their IS instead. Great to have it back again, as I guess I am a traditionalist at heart and enjoy the IS more than the pop songs. After IS sounded like National Anthem. Doing well by the usual 0359 drums; more time pips (5+1) and into the news in Swahili; almost fair at times. So will the playing of the IS become a regular feature now? (Ron Howard, Asilomar State Beach, CA)
6015	Feb26	*0256-	ZBC Radio. No IS today, as heard the last two days; instead back to Spice FM pop African music intro till 0300 time pips; 0301 reciting from the Qur'an; almost fair (Ron Howard, Asilomar State Beach, CA, USA)
6015	Feb25	*0258-	ZBC Radio. Indeed another sign on with their distinctive, repetitive xylophone or marimba sounding IS, as noted being used for the first time in a long time yesterday; poor (Ron Howard, Asilomar State Beach, CA, USA)
6015	Feb27	2014	ZBC Radio 0252-0306. Hoping to hear their old IS as recently reported by Ron Howard (thanks Ron), tuned in at 0252, only to find Spice FM. Lots of talk with an apparent party atmosphere, but into pop music at 0259. 5+1 time pips at 0300, morning greetings in Swahili and ID "ZBC". Koran at 0301, back to normal talk at 0305 but with several mentions of "Koran". So, as Ron reported yesterday (Feb 26) they are back to normal routine. Good reception though. Jo'burg sunrise 0400 (Bill Bingham, Johannesburg RSA. Sony ICF2001D. dxldyg via DXLD)
6055	Feb15	1714	R. Rwanda, Kigali, dialecto local, texto, canções; 35433. Carlos Gonçalves
6055	Feb25	1501	Radio Rwanda. Listening to hear if they re-instated the multi-language news headlines, but they have not. Just news in detail (assume Kinyarwanda) from 1501 to 1508, followed by series of ads and into pop African songs. Via long path. I miss the headlines in English! (Ron Howard, Asilomar State Beach, CA, USA)

6055	Feb23	2029	Radio Rwanda, Kigali, Vn, Afro songs, good (BOC 32 Monferini & Bernardini)
6069, 96	Feb21	2330	CFRX, Toronto, Kanada. Nice signal from CFRX the last days after 23 UT on 6069,96. After 0 UT Cuba is on 6070... And a friendly QSL Service from Steve Canney/ODXA: cfrx@ymail.com http://www.cfrx.webs.com SIO 353 Christoph Ratzer
6070	Feb20	0634	can't make out any signal from CFRX: hope they aren't gone again. Never has regained usual strength they enjoyed before last crash. Need to keep an ear on 6070, especially just before Cuba blox around 0000 UT (Glenn Hauser, OK)
6070	Feb15	2303	CFRX, Toronto ON, retransmissão da DFRB, inglês, texto, entrevistas; 24331. Carlos Gonçalves
6070-	Feb20	2357	checking for CFRX Toronto: yes, it's there, but poor signal, and also storm noise from nearby. After ads, ``In-depth radio, News-Talk 10-10, CFRB, Toronto``. Also has splatter from 6060 Cuba, especially when IS plays at 0000. CFRX talkshow runs past hourtop, 0000:40 Feb 21 on to news and weather, but RHC 6070 carrier *0000:55 blots it, starting weakly and rapidly ramping up to full power, adding modulation at 0001:40 from the music-fill hour. See also CUBA (Glenn Hauser, OK)
6089,82	Feb22	1841	Radio Nigeria, Kaduna, talks Vn, weak, free channel (BOC 32 Monferini & Bernardini)
6089,9	Feb15	-2300*	R. Nigeria, Kaduna dialecto local, texto, anúncio da pág. ^a internet da emissora; 54433, QRM de AIA. Carlos Gonçalves
6105	Feb14	2142	R. Filadélfia, A Voz do Brasil; 33432, QRM adjacente. Carlos Gonçalves
6130	Feb23	2030	Unid in French, talks, politics too, weak, at 2045 under PBS Tibet carrier opening at 2050 (BOC 32 Monferini & Bernardini)
6130	Feb23	*2050-	PBS Xizang, China, start bc Tibetan, id also in English, good (BOC 32 Monferini & Bernardini)
6134,80	Feb26	-0208*	R. Santa Cruz. Usual sign off format; almost fair; no het (Ron Howard, Asilomar State Beach, CA, USA)
6134,8	Mar2	0058	Once again rumbling lo het caused by R. Aparecida, BRAZIL, approaching closely but not exactly to R. Santa Cruz's less variable frequency. About equal level here now, making both unusable, and presumably even more so in South America (Glenn Hauser, OK)
6135,6	Feb14	2145	R. Aparecida, Aparecida SP, A Voz do Brasil e, às 2202, o progr. Com a Mãe Aparecida; 44433. Carlos Gonçalves
6137,4	Feb21	0015	R. Aparecida has varied further up; could it be deliberate to avoid 6134.8 Bolivia? They are certainly more separable now, especially since R. Santa Cruz is quite weak by comparison. This should also keep it a safe distance from Romania 6145 after 0100 in English. Otherwise might as well go to 6140 where there is nothing at all here in the evenings. Then I check the other Aparecida frequencies: // 9629.76 approx. at 0023 is best, mentioning flagship show ``Com a Mãe Aparecida``, but less flutter on // 11854.82 approx. 5035: too much QubaRM (Glenn Hauser, OK)
6160	Feb13	2311	CKZN, São João da Terra Nova, inglês, entrevista a respeito da Universidade de Montana (EUA), relatos informativos; 45433, // 1400 CBG, Gander. Carlos Gonçalves
6170	Mar1	1045	Scandinavian Weekend R, Virrat Finnish talk, pop songs 25232 // 11720 (25222) AP-DNK
6180	Mar1	2130	R Nacional Amazonica med fotboll. 21.43 blev det mål och reportern blev jätteglad. Q4. DO
6215	Feb19	1750	Carmen R spelade gamla godingar som Pet Shop Boys, ELO och Shaka Khan. DO
6300	Feb18	1755	State of Unrest stängde 18.20. Hördes inte bra här. Q 2. DO
6308	Feb20	1745	R Mir med anrop på ukrainska i övrigt popmusik som "Accidents never happen" med Blondie. DO
6322	Feb22	1800	R Experience med Cher och Aprodites Child i programmet. DO
6325	Feb16	1935	R. Bogusman (p), G, música pop!; 45433. Carlos Gonçalves
7120	Feb22	1830	Radio Hargeisa, Somaliland, long talks, Somali, fair in USB to avoid Hams (BOC 32 Monferini & Bernardini)
7265	Mar1	1340	Hamburger Lokal Radio, Göhren German ann, pop song, interview with Gustav Winter - only in AM and USB! 45444 AP-DNK
7265	Feb22	1340	R City, via Göhren English ann "on 7265", Mexican songs, English lovesong 55454 AP-DNK
7295	Feb22	2150	Traxx FM, Malaysia, songs, talks, ids, good (BOC 32 Monferini & Bernardini)
9420	Feb25	1400	CNR 13 Lingshi hördes med Q 2 i USB. DO
9545	Feb17	0842	SIBC - Voice of the Nation. Good; "service messages," "from Blue Ocean Shipping Co. Ltd. . . LC Dragon will be making a trip on Thursday . . ." Very clear audio at https://app.box.com/s/in102j2pim9w69zrcdn6 (Ron Howard, San Francisco at Ocean Beach, CA, USA)
9545	Feb25	1328	SIBC. Checking on Feb 25 after 1328 could not hear the normal open carrier. Have they actually stopped leaving the tx on after programming ends at 1200? Would think doing so would save them considerable money? (Ron Howard, Asilomar State Beach, CA, USA)

9635,7	Feb15	1140	R. Voz do Vietname, Son Tay, 1111-desvan. total 1140, 15/2, texto; 15421. Carlos Gonçalves
9825	Feb24	-1930*	Radio Pilipinas, Tinang, talks in Tagalog, ids, off 1930, good (BOC 32 Monferini & Bernardini)
9835	Feb24	1933	Sarawak FM, Malaysia, nice songs, ids, good (BOC 32 Monferini & Bernardini)
9965	Feb24	1948	Radio Thailand, Udon Thani, news also about Italian football, English, id also as "88 FM global news", excellent (BOC 32 Monferini & Bernardini)
11735	Feb23	1910	ZBC Radio, Zanzibar, Tanzania, talks Swahili, at 1915 silence for 1 min, good (BOC 32 Monferini & Bernardini)
11980,10	Feb9	0815	Dniprovska Khvyliya, Zaporizhia Ukrainian talk mentioning Ukraine, song by choir 25232 AP-DNK
11981	Mar1	0810	Dniprovska Hvyliya (Wave of Dniestr), Zaporizhia, Ukraina låter inte som en pirat. Mycket prat om Ukraina, men däremellan spelades också ballader på ryska. Tidvis riktigt bra i AM-mode, men ligger snett och brett. Oftast är det dock en massa "støj", så det låter nästan som en slags spegelfrekvens. Finns noterad med adress i årets WRTH. BEFF
12085		1045	VoMNG Japanisch. Um 1045 UT in Süddeutschland, Schweiz, Italien eher dürftig schwaches Signal S=4. Dagegen in Finland, Stockholm und Moskau S=7-8, und in Tokyo Japan S=9+10dB, aber dort praktisch als Lokalsignal hört man die Schwäche der Modulation / Übertragung, ein ganz unsauberer kratzender und clippender Feed. Da gehört entweder die Senderöhre mal erneuert oder der Zuführungsfeed liegt neben dem Kanal. (73 wb via A-DX)
15000	Mar1	1600	Amici Italcable från Viareggio gick bäst i USB och tidvis riktigt bra. CW-signaler, tidsangivelser på italienska och oannonserad musik (t ex en orkestral version av jazziga "Take Five"). BEFF
15140	Feb24	1441	R. Sultanate of Oman. Nice signal, but light het; in English with "Herbs and Health" program all about the benefits of eating dates; "90.4 FM" IDs (Ron Howard, Asilomar State Beach, CA, USA)
15190	Feb24		KTWR. Very brief opening with preaching in English; quickly became unusable (Ron Howard, Asilomar State Beach, CA, USA)
15215	Feb21	-1658*	R Öömrang, via Wertachtal Annual broadcast in Frisian, Hoch German and English talks from a party with much laughter 54544 AP-DNK
15515	Mar1	1500	Radio Warra Wangeela-ti (lär betyda "Evangelic Church") med sändning via NEXUS-IRRS på Oromo. Riktat sig till Etiopien och spelar mellan snackelådorna vacker musik från Afrikas Horn. Är av någon anledning utsatt för jamming, så hörbarheten är störd, trots god styrka. Jag testat med att skicka en rapport via Oromo Evangelical Church i Trondheim! BEFF
17540	Feb26	1700	Radio Impala (via Madagaskar) - trevlig musik och däremellan tal om demokrati (eller bristen på densamma) i Rwanda. 3-4 CB
17660	Feb24	1520	Radio Saoudienne Internationale med inslag om en arkitekt på franska. Man annonserar nu ett nytt namn på stationen. 3 CB

Mysterious carrier on 3210

It was very good conds towards Australia on Feb 24. The best reception here towards that area is at about 2000z at this time of the year.

I checked in my Perseus recording starting 1956z for the new transmitter on 3210. Believe it or not but this only date there was a carrier. Checked with my antennas and the direction was pointing towards that area.

As you can see there is some sort of activity around this frequency, probably Codar???

Anyhow, very interesting so please keep an eye here.

(Thomas Nilsson)

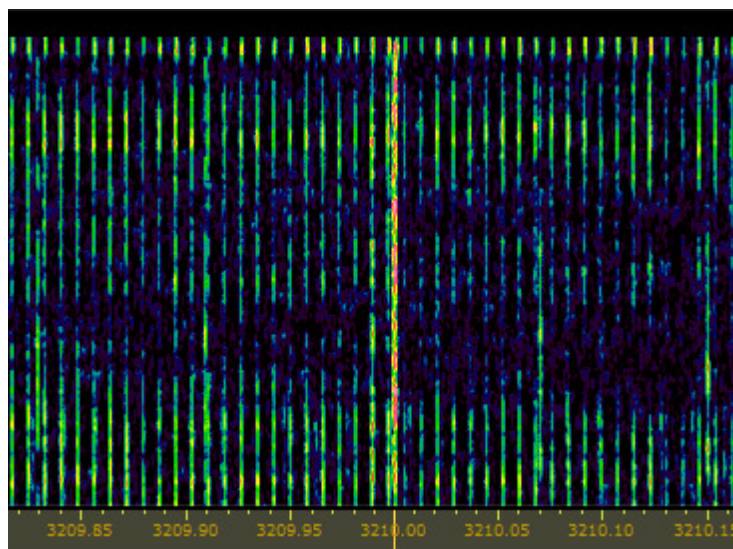

Station news

AUSTRALIA. New SW transmissions on 3210 kHz --- For those that can recall, the earlier test transmissions on 3210 kHz were from Aussie broadcaster - OzyRadio as operated by owner Craig Allen. These transmissions emanated from a place known as Schofields, an outer Sydney suburb in the north west near Richmond, NSW.

The Schofields SW transmission site has long since been dismantled, but as many of you will be aware the transmissions on 3210 kHz resumed last week. This time under a new station name & from a new transmitter site.

Craig is still the owner of the licence and still owns the transmission equipment; however a new leasing arrangement between Vintage FM and Craig currently sees Vintage FM programming carried on some of Craig's FM licences and just this last week on 3210 kHz SW. The new transmitter site is located in an area I best associate as the township named Picton, NSW - just past the outer fringes of south west Sydney.

I recently caught up with Craig and some of the ARDXC lads, where we enquired further about Craig's recent SW broadcasting developments & licences.

Craig tells us that the current power on 3210 kHz is around 250 W and that when he corrects a SWR problem with the antenna he'll hopefully increase the power in the near future. Like most SW broadcasters these days, rising electricity costs is a hindrance and it's an issue with Craig as well.

We asked about the program he currently has on 3210 kHz. Craig has a license lease arrangement with Vintage FM on 88.7 MHz from the same site that he is broadcasting with on 3210 kHz. Vintage FM has been operating as a LPON 1 Watt broadcast station operating from studios in the Penrith area for around 5 years and broadcasts a 50's - 60's music format of well known hits and radio dramas from that era. Currently 3210 kHz is broadcasting 24 hours a day.

DXers have enquired about the former licence and frequency of 5050 kHz that was used a couple of years ago by Ozyradio. Craig is well aware that this SW channel is rather congested and does want to change the frequency to another nearby 60 mb frequency. To do that he needs to find another SW frequency and lodge an application with the ACMA for a frequency change.

Craig wants feedback and suggestions from the SWL and DXer community!

1. Craig is thinking about usage of 5045 kHz as an alternative to 5050 and welcomes comments regarding this possible choice of frequency or welcomes other nearby suitable frequency suggestions. There is also a local Australian issue whereby some Shortwave outback 2-way telephone services are using frequencies in or about the 60mb. Anyway please give Craig your suggestions or send via my email. The sooner we get this issue sorted the sooner we'll get to hear Ozyradio back on 60 meters :-)

2. Craig intends to have other programming, (other than Vintage FM) carried on 60 meters. Craig is keen to know what kind of programming that you as a SWLer/dxer would listen to and find appealing.

3. Craig is pondering with the idea of having a DRM transmission on 60 meters and would welcome comments. Craig is all too well aware of the lack of DRM receivers on the market and the fact that most DXers use SDRs for DRM.

It was interesting speaking with Craig. He tells us that so far All India Radio have not received a single application to their released tender for the manufacture of DRM receivers. My own personal thoughts on this issue was that the world has hoping that India's drive towards DRM would drive and entice radio receiver manufacturers to start producing some DRM portable and table top SW/MW DRM receivers.

In the issuing of QSL's or eQSLs by OzyRadio, several of us got involved on this topic. I understand that any reception reports sent to Vintage FM for 3210 kHz reception will be passed onto to Craig. Hopefully in the not too distant future we will be able to organise something for DXers. It's still early days. And if you haven't yet guessed, Ozyradio on SW is very much a hobby interest for Craig. He has other work commitments and it does cost money to operate the station.

I hope to be able report more throughout 2014 about the station. For the moment please show your support with program and reception feedback on 3210 kHz and PLEASE provide your feedback suggestions for:

1. Clear Frequency on 60mb and if 5045 kHz is suitable in your area?
2. Program format or program suggestion for future 60mb outlet, something that you would like to listen to.
3. Your thoughts about DRM usage on 60 mb; I could only imagine that this would only be heard in Australia or possibly NZ at best.

(Ian Baxter, NSW, Feb 24, shortwavesites yg via DXLD)

Craig Allen (owner of the station on 3210 kHz.) thanked me for my report. "Good to see we are making it to the USA. We are running 200 watts (licenced for 1kw). When we improve our antenna, we may increase the power. We will try to get a frequency change from 5050 to 5045 or 5055." He asked what I thought best and I responded that either 5045 or 5055 would be 100% better than his former 5050. This due to the fact that I hear China (fairly strong) and India (weak) currently mixing together on 5050 during my listening from about 1230 to 1500 UT. Think either frequency would be fine.
(Ron Howard)

RWANDA. **Rwanda Broadcasting Agency** is the new name for that country's state radio and television organisation, and they have a slick new website and URL at www.rba.co.rw. The site is presented in English, French and Kinyarwanda and offers live streams and on-demand archive files of their Rwanda TV and Radio Rwanda services, in addition to live streaming of Magic FM. There are also frequency details of five RBA community radio stations. Via DXLD

Other radio news

CHASQUI DX PFA – FEBRERO 2014

CQ, CQ, CQ...Aquí Pedro F. Arrunátegui para compartir algo con los que disfrutan y aman el DX latinoamericano, todas las horas son UTC, desde la tierra de los incas, les informo mediante este Quipus lo siguiente:

- 1030.00 COLOMBIA, R. Antena 2, Cali, 0601-0620 33333** news deportivas ID "Este periodista de Antena 2 de RCN" news ID "En Antena 2 Colombia, en la redacción deportiva de Fanáticos de la noche". **NOTA:** Por momentos se cruza con R. Eco Antena de Guayaquil
- 1190.96 COLOMBIA, R. Cordillera, Bogotá, 30/01 0625-0640 33333** mx px Música para recordar ID "En Radio Cordillera" mx ID "Son Nuestros Artista.. Radio Cordillera es Todelar" advs maneja con cuidado es una campaña de Todelar ID "Escucha Radio Cordillera 1190AM, la música popular está en Todelar".
- 4747.20 PERÚ, R. Huanta 2000, Huanta; 15/02 1120-1145 33333** mx huayno ID "Radio Huanta 2000 una experiencia diferente" mx ID "Transmite de Huanta la bella esmeralda de los andes Radio Huanta 2000" **NOTA antes 4747.05 ahora 4747.20**
- 4774.90 PERÚ, R. Tarma, Tarma, Junín; 1/02 2155-2220 44444** mx ID "Radio Tarma la internacional" mx huayno huarachirana . ID "Con la mejor música Radio Tarma"
- 4789.87 PERÚ, R. Visión, Chiclayo; 29/01 0940-1002 33333** px religioso Dios es Amor mx religiosa y advs sobre otras campañas religiosas desde Iglesia Pentecostal La Cosecha en Chiclayo.
- 4824.48 PERÚ, R. La Voz de la Selva, Iquitos, 27/01 0005-0035 33333+** px en español sobre la juventud mx moderna **NOTA:** por momentos se le pierde la señal.
- 4865.00 BRASIL, R. Verde Florestas, Acre; 6/02 1105-1140 44444+** mx tocan mx en forma continua ID Completo ID "Radio Verde Floresta" escuchar grabación adjunta.
- 4875.00 BRASIL, R. Dif. Roraima, Boa Vista, 29/01 1006- 1030 22222** mx y news mx y advs ID "En la frecuencia de 4875 kHz y 590 onda media, Radio Difusora .. Brasil.." **NOTA:** a las **1024 hay bastante ruido y ellos quedan de fondo**
- 4939.98 PERÚ, R. San Antonio, Atalaya, Ucayali; 0235-0310 44444** advs Aviso del Consejo Provincial de Atalaya mx tropical y moderna **NOTA:** constantemente dan la señal horaria pero no dan el ID. px religioso.
- 4955.00 PERU, R. Cultural Amauta, Huanta; 16/02 1110-1140 44444+** px religioso mx ID "Desde la ciudad la ciudad de Huanta, transmite Radio Cultural Amauta en FM 99.9 Estéreo" mx huayno px en quechua
- 5035.00 BRASIL, R. Aparecida, Aparecida; 12/02 2302-2338 22222** px religioso sobre la Virgen Aparecida, fue necesario escucharla en LSB ID "Radio Aparecida"
- 5039.14 PERÚ, R. Libertad, Junín; 3/02 1120-1205 44444** mx advs Se presenta en esta ciudad Vicente de los Milagros conocedor de las yerbas curativas en San Martín 552 Barrio San Cristóbal Este, Junín ID "Ahora la repuesta es... yo escucho Radio Libertad" Junín. Farma Internacional px Avisos y Comunicado El Consejo Provincial de Junín comunica cumplir.. px El Noticiero Libertad news **NOTA: varios meses que no lo escuchaba , Frecuencia verificada, ahora en 5039.14 antes 5039.20.**
- 5459.95 PERÚ, R. Bolívar (ex R. La Voz de Bolívar), Bolívar, Trujillo; 14/02 0010-0105 33333++** ID "Buenas noche, el gerente de Radio Bolívar" px Saludos y mensajes ID "Buenas noches, Radio Bolívar" comunican están probando los equipos ID "Radio Bolívar Imparable" , infórmenos como nos escuchan al teléfono 976991597 ID "Radio Bolívar insuperable" También el 15/02 1055-1115 para verificar si salen en la mañana y no hay señal alguna. **NOTA:** los llame por el número de celular que indican y me informan que están en calidad de prueba, que su ingeniero está ajustando los equipos y que luego informaran su horario de trabajo. Esta estación hace mucho tiempo



que no se le escucha, antes en su ID decían Radio La Voz de Bolívar, hoy solo dicen Radio Bolívar. Frecuencia verificada en 5459.95 (tnx R. Wilkner)

- 5910.06 COLOMBIA, Alcaraván radio, Puerto Lleras; 17/02 1032-1100 33333+ mx px religioso ID 1530AM Alcaraván radio" mx ID "En su dial 1530AM y 5910kHz en onda corta Alcaraván radio, desde Colombia" mx ID "En Alcaraván radio" mx continuamos con nuestro folclor y su música.**
- 5939.86 BRASIL, R. Voz Misionaria, Camboriú, SC, 2/02 2325-2345 33333 px religioso Dios es amor ID "Voz Misionaria, Radio Voz Misionaria 5940kHz.. Voz Misionaria" (escuchar grabación)**
- 5952.40 BOLIVIA, R. Pio XII, Siglo XX, 10/02 2329-0005+ 44444 mxf px en quechua advs Politécnico Agropecuario Simón Bolívar news en quechua y español en cadena con Radio Arco Iris.. mx advs Universidad Nacional Siglo XII ID "Pio XII, la radio que hace pueblo...Pio XII". NOTA: ahora 5952.40 antes 5952.50**
- 5970.00 BRASIL, R. Itatiaia, Bello Horizonte; 11/02 2330-0005 33333 advs mx px transmisión de partido de fútbol NOTA: No dan ID.**
- 6025.00 BOLIVIA, R. Patria Nueva, La Paz, 12/02 2345-0010 44444+ px Noticiero Bolivia Informa para el sistema de Patria Nueva news varias en español y quechua ID "Faltan 10 minutos para las 8 de la noche en Patria Nueva" ID "Un mensaje de solidaridad de Patria Nueva" NOTA: adjunto slogan musical de la radio que por primera vez la escucho, muy bonita, escúchenla Slogan " Es Patria Nueva, desde Bolivia por la unidad e integración, informaciones, gran compañía, tu escucharas, es Patria Nueva contigo esta .."**
- 6080.00 BRASIL, R. Marumby, Curitiba, PR, 2/02 2350-0010 33333+ mx con motivo religioso IDRadio Marumby..... Marumby (canción), (escuchar grabación adjunta) mx religiosa.**
- 6173.90 PERÚ, R. Tawuantinsuyo, Cusco; 1/02 2130-2150 44444 mxf ID "Atención a la planta de Radio Tawuantinsuyo, estamos entrando entre cortados" mxf en quechua y español ID "Transmite Radio Tawuantinsuyo desde Cusco" mxf.**
- 6180.00 BRASIL, R. Nacional da Amazonia, Brasilia; 3/02 2335-2350 44444++ px transmisión deportivo de básquet Flamengo con Minas // 11780.**
- 9515.00 BRASIL, R. Novas de Paz, Curitiba; 3/02 0015-0045 44444 varias políticas y deportivas mx, no escucho ID**
- 11780.00 BRASIL, R. Nacional da Amazonia, Brasilia; 3/02 2330-2350 44444 en // 6180kHz ID "Radio Nacional (escuchar grabación) px momentos musicales mx**



La recepción la he efectuado del 27/01 al 17/02 en compañía de mi sabueso Icom IC R72 acompañado del Mizuho KX-3, una antena de hilo largo de 12 metros y una antena loop. Recuerden que las grabaciones que adjunto, serán mejor escuchadas con los audífonos.

Muchos 128's, PFA

Perseus waterfall

Just as a comment on this subject, I see many Perseus waterfall screen captures that have a significant amount of Averaging applied. I don't EVER use averaging on the waterfall (alho I prefer a little bit on the spectrum display) as I want "see" as deep into the signal as I can and I'm not sure why one would want to reduce the great screen resolution that you mentioned. The other feature that I almost never see mentioned is the ability to remove things like the visual streak made by a lightning strike (using Auto1 and Legacy). I have other SDR's and have tried various other programmes but I find myself always feeling more comfortable using the native Perseus software. The fact that it doesn't resize isn't a concern for me.

(73 Don, VE6JY via Perseus_SDR)

That's interesting. I always wondered what the differences are between those setting. I never found descriptions about them (Jurgen Bartels Suellwarden, N. Germany, via Perseus_SDR)

In the jungle, the mighty jungle...

Har äntligen fått tummarna loss att skriva några rader om min resa. Sitter nu på flygplatsen i Iquitos. Jag har några dagar över innan jag hade tänkt bege mig till regniga och kalla Cusco så jag kollade upp lite olika varmare ställen att åka till först men valet föll ändå på att återvända till Pucallpa. Det ligger på vägen till Lima så jag slipper onödiga utgifter och långa väntetider vilket verkar vara normen för inrikesflygen i Peru.

Först lite om Iquitos. Det har alltid varit en dröm att åka hit till den största staden i världen som inte går att nå landvägen. En halv miljon människor bor här, omgivna av ogenomtränglig djungel. Och det är verkligen en intressant stad. En lång strandpromenad, Malecón, leder utmed Amazonfloden där mängder med folk samlas på kvällarna för att se olika

uppträdanden och titta på folkvimlet. Det råder ett totalt kaos med ett oräkneligt antal mototaxis, vilket ungefär kan beskrivas som trehjuliga mopedtaxi.

Jag hade dock inte riktigt räknat med att den skulle vara så pass turistig. Många kommer hit för att ta sig en bit eller genom hela Amazonas till dess mynning i Belém i Brasilien. Det finns ett ganska stort antal västerländska äldre herrar varav den ene märkligare än den andre som har slagit sig ner här. De allra flesta turisterna är dock yngre backpackers och hippies med dreadlocks, batikkläder, skägg och halsband som främst kommer till Iquitos för att ta ayahuasca. Det är en hallucinogen drog som shamanerna hos indianstammarna i djungeln tar för att komma i kontakt med andevärlden. Det är inte olagligt här och det har nu blivit en del av den så kallade "gringo trail" att åka hit och tillbringa några dagar hos en shaman, men många gånger är det inte en riktig shaman utan någon som bara utger sig för att vara det. Många av de peruaner som jag pratat med förstår att detta ger inkomster till staden och till små indianbyar men säger samtidigt att för många här är det något heligt att ta ayahuasca och enbart till för shamaner eller för speciella ceremonier.

Jag tröttnade snabbt på alla dessa personer som försöker vara speciella och på allt det negativa som ofta följer i fotspåren av ett stort antal turister, såsom jobbiga försäljare och efterhängsna personer som vill erbjuda en både ditt och datt. Jag bytte hotell från ett mitt i smeten till ett i ett ytterområde av staden och fick på så sätt genast mer av det som jag sökte - det genuina Iquitos med vänliga människor utan någon baktanke när de pratar med en. Problemet var bara att hela släkten till hotellets ägarinna var på besök och de tvingade mig att dricka stora mängder öl varje kväll, vilket gjort att jag varit konstant trött i Iquitos.

Den andra anledningen till att folk kommer hit är naturligtvis Amazonas. Det går att göra otroliga turer ut i djungeln men för att verkligen se varierat djurliv och besöka indianstammar måste man långt bort från staden och tyvärr hade jag inte riktigt denna tid. Det finns dock massor att se inom några timmars färd från Iquitos. Jag har varit på ett flertal så kallade animal rescue centers, där man tar hand om djur som farit illa eller utrotningshotade djur som varit till salu på marknader. Det finns ofta några tama djur som visas upp för turister och om man har tur så kan man få hålla en anaconda eller ha apor klättrande över sig. Jag har också handmatat manater och besökt indianbyar i närheten. Dessa byar ingår i många resebyråers djungelturer så det är väldigt turistigt men många kvinnor går i varje fall barbystade.

Jag är mycket nöjd över mitt besök i Iquitos men det visade sig att Pucallpa mycket mer motsvarade det som jag ville uppleva i Perus djungel. Jag visste i stort sett ingenting om staden men jag såg att planet till Iquitos gjorde ett stopp där så jag beslöt mig för att se vad det var för något. Pucallpa ligger inte utmed Amazonfloden utan istället Ucayali, vilken senare rinner ut i Amazonas. Det är ett konstant myller av folk vid hamnen där det lastas av bananer och diverse märkliga saker. Indianer i färgglada dresser kommer in till staden för att sälja frukt och antalet mototaxis är ännu större än i Iquitos. Pucallpa ligger också i Perus kokainproducerande del och man kan se specialförband bege sig ut i djungeln för att förstöra kokainfabriker. Peru har numera gått om Colombia som den största kokainproducenten. Det råder en mycket mer påtaglig "frontier feeling" i Pucallpa än i Iquitos och det var den som jag ville komma åt. Jag hittade en reseskildring på nätet som ganska bra beskriver staden: "Pucallpa is a noisy, dirty, dusty, rubbish-strewn, crime-ridden city. It is also the ugliest city I know" och "it is a place so dismal that within hours of arriving I had booked passage to Iquitos".

Folk är dock oerhört vänliga, faktiskt bland de vänligare som jag har stött på under mina resor. De är genuint intresserade av vem jag är och det är i stort sett helt befriat från jobbiga och efterhängsna personer. En kort resa med mototaxi utanför staden ligger en sjö vid namn Yarinacocha. Byn består av fallfärdiga ruckel men det finns en liten gata med restauranger och barer där man kan äta fantastisk god fisk och cumbiamusiken står på högsta volym. Man kan hyra kanoter med motorer, så kallade peki-pekis, som kan ta en till små byar kring sjön. På vägen kan man se rosaaktiga sötvattensdelfiner hoppa runt båten och i träden finns apor och sengångare. Att bada kanske man ska vara försiktig med eftersom det finns pirayor i sjön.

Det var lite om livet här i Perus djungel. Jag skriver mer vid ett senare tillfälle. Jag har nu anlänt till Pucallpa efter en av de värsta flygturerna i mitt liv. Det var inte bara skakigt på grund av turbulens utan mer som planet hoppade upp och ner hela tiden. Under oss såg man bara djungel så där kände man sig ganska liten. Såg nu också att jag fått ett mail från pappa om att Anders haft inbrott. Hoppas det gick bra. Angående Cusco så ska jag kolla upp lite mer om det inom de närmsta dagarna.

Här kommer en liten kort uppdatering.

Är nu i Cusco, på 3400 meters höjd. Det är stora demonstrationer runt om i staden. Har inte riktigt blivit klok på varför de protesterar men vägen till och från flygplatsen blockerades precis när jag skulle bege mig därifrån så kunde inte ta en taxi till mitt hotell. Jag frågade några kvinnliga poliser om hur jag skulle göra och det slutade med att jag fick den enes nummer och att jag fick lift med en polisbil till hotellet. Så kan det gå. Poliserna gjorde sig nog en rejäl hacka på det när jag gav dem pengar som tack för skjutsen. Flera vägar var avskurna med brinnande bildäck och diverse bråte.

Nu är jag i varje fall äntligen på mitt hotell och imorgon blir det Machu Picchu förhoppningsvis om inte det är problem på grund av demonstrationerna.

Ska höra av mig till Carlos Gamarra. Fredag hade passat bra att träffa honom. Annars är allt bra här. Har varit i Pucallpa fram till igår och sov i Lima inatt.

Bara en kort uppdatering igen. Sitter nu på ett café på flygplatsen i Lima efter att ha kommit hit från Cusco idag. Det var verkligen värt att åka till Cusco trots regn, kyla och massturism. Machu Picchu är en magnifik plats! Tyvärr fick jag inte kontakt med Carlos Gamarra. Jag hade ju bara två och en halv dag i Cusco och den halva dagen gick bort i och med demonstrationerna och en heldag gick åt till Machu Picchu. Igår gick jag till adressen Avenida Garcilaso som jag fått i mailet men det såg väldigt dött ut. Hade väntat mig en radiostation där så jag frågade lite folk om det men ingen visste någonting. Jag kollade i mailet igen när jag kom hem och kanske är det hans hemadress istället. Jag ringde numret men det fungerade inte. Hade såklart varit bättre att maila honom och bestämt träff. Lite tråkigt men svårt med så begränsad tid.



Cusco ligger förresten fantastiskt i en dalgång och stadskärnan är verkligen vacker. Dock är det en smula för turistigt för mig. Mängder med backpackers och japaner men jag träffade några trevliga chilenskor som jag var ute och åt med. Har som vanligt bytat runt på mina biljetter. Jag flyger inte längre hem från Barbados på onsdag utan från Lima på torsdag. Det blev lite väl dyrt med flera byten för att resa härifrån till Karibien för bara några få dagar. Om några timmar åker jag tillbaka till Pucallpa och ska bara hänga där och njuta av mina sista dagar i Peru utan att flänga runt allt för mycket och dricka öl, bada i poolen och äta grillad fisk.

(Jesper Nilsson)

Remote MW-DX-Karvia

On this blog we introduce our remote-controlled Medium Wave- DX-station located in Karvia in midwest Finland. The DX-site is owned and installed by **Kimmo Vuorela** (KIV, Helsinki) and **Harri Kujala** (HKU, Naantali).

This is based on our remote-FM-DX-sites located in Utö- and Jurmo-islands in southwest Finland in the past years. We have this same equipment at summertime for FM and at wintertime for AM.

Mail: harriku@at/dnainternet.net

On this blog we introduce our low-tech remote-site for Medium Wave-DXing. This station is located in midwest Finland in Karvia's countryside.

We remote this site with **3G-wireless USB-stick-connections** and control the computers with **LogMeIn**- software. Live-audio is transferred with **Skype** (on both ends).

Both DXers have own **Perseus SDR-receiver** and can choose the antenna separately with **USB-switchers** (Denkovi and Velleman USB-relays switchers).

The computers are remote started with **Nokia 3110-phone** connected to **PG11 relay-box** (Probyte Oy).

Typing number-code to the phone it starts computer with short relay-connection. Computer make internet connection automatically when starting.

The 4 antennas are directed to Americas: 250, 275, 305 degrees each 800 m long. Antenna 325 degrees is not finalized and not in use yet). 250 and 275 antennas are 800 m long aluminum-wires. Others Cu. Antennas are grounded at the end with 500 Ohm resistors and 1 m thick metal tubes under ground.

The wires are matched with 4 baluns and signal is fed to receivers with 4 x 200 m coax cables.

At receiver point we have **Medium Wave-amplifier** and **splitter** for two receivers.

This same equipment is installed at summertimes for FM to southwest Finland in distant island Utö (and Jurmo). For the first time it is now moved for AM-DXing for wintertime.

Here below some photos from August (antenna work) and November 2013. See <http://mwdx-karvia.blogspot.se/>

Kilimanjaro log & WB-files

On a recent visit to Kilimanjaro, Tanzania, we brought along an SDR-IQ to check out the East African MW scene. Recordings were made on five different locations on or near Kilimanjaro. The RF files along with a preliminary log are available.

Details can be found here <http://arcticdx.blogspot.no/2014/02/kili1-master-log-rf-recordings-ready.html>.

(Regards, Bjarne Mjelde & OJS, <http://arcticdx.blogspot.se/>)

5 Volt power supply for Perseus

Building one will be great! Trust me. Use two regulators 12v to 9v and then 9v to 5v. Add RF filtering.
(73, Sudipta Ghose, VU3TKG via Perseus_SDR)

Hello Sudipta, A word of warning is on order here. Using two regulators can work fine. However, I have build a power supply for feeding my PERSEUS from a 12 V battery, using two regulators. It appeared that when it was switched on, the output gave a voltage peak of well above 5V. I had over-voltage protecting build in, which saved my PERSEUS. So, I changed to a single 5V regulator with a nice heatsink and all is fine now!
(73, Roelof Bakker, pa0rdt via Perseus_SDR)

I have been powering my Perseus from my laptop using the double usb plug cord assembly that was described on the website by Guido Schotmans months ago. It has worked flawlessly and measured dc voltage is 5 volts within a tenth of a volt. I have not seen any comments on this power method and wonder if it is not recommended.
(73, Bill WA2DVU Cape May, NJ via Perseus_SDR)

Bill, I'm using this method when operating Perseus portable. Works fine.
(Regards Werner Karn via Perseus_SDR)

Double USB Plug for Perseus

Wire colour code is correct for most usb cables but some brands use different colours. Make sure to measure them before use !

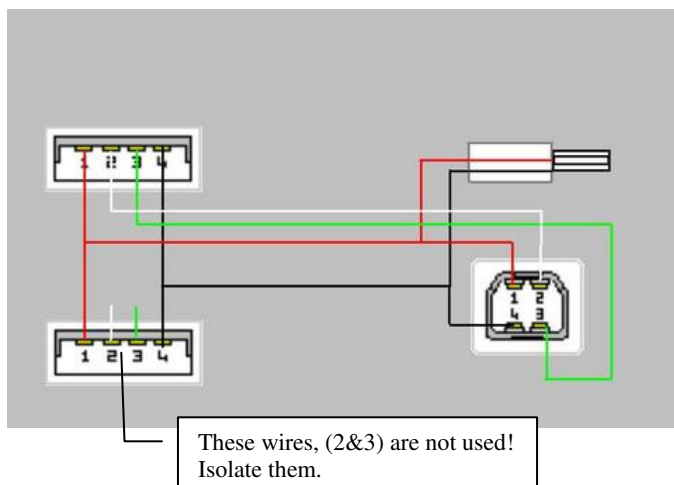

This is how the cable looks like.

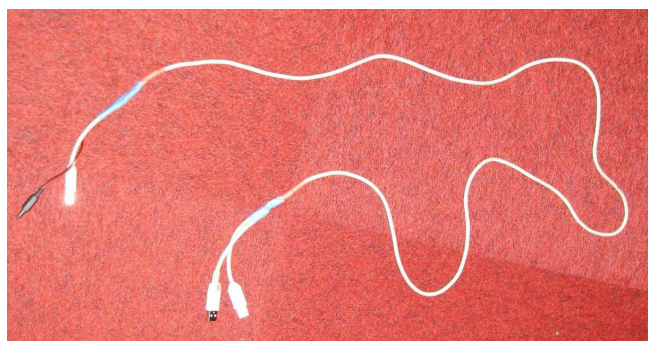

Always connect the USB connectors first to the computer and then the USB one and the DC-connector to the Perseus. Otherwise there is a chance that your computer will switch off the usb port and you will have to reboot.

BTW : I don't take any responsibility if you damage your PC or Perseus.
(73, Guido Schotmans.)

Guido, thanks a lot for sharing this schematic and comments with us! /Thomas

Uppgradering av en Dell Studio 540 dator

Det senaste året har jag märkt en rejäl försämring när de största Perseus inspelningarna skall lyssnas av. Det har blivit mycket hack och knäppar och så fort Outlook tagit emot mail så har hårddisken knorrat till med ett antal knäppar en period för att sedan gå bra igen ett tag. Likaså när man förflyttat sig i inspelningen har det också låtit likadant. Det funkar inte heller bra att spela upp direkt från en 2 Tb extern USB 2 disk. Det blir också mycket hackande och knäppande.

Likaså när man spelade upp en fil så hackade det alltid till ett antal gånger innan uppspelningen gick normalt. Jag noterade att samtidigt som hackandet kom så gick processorn upp till från ett par % till c:a 25% belastning för att sen gå ner när hackandet försvann. Detta tyder på att den interna bussöverföringen inte fungerar som den skall och att processorn inte klarar av bearbetningen av data.

Datorn är en Dell Studio 540 Win 7 32-bitars, 4 GB minne, Intel Quad CPU Q8200 @ 2,4 GHz från 2009. I datorn sitter en Seagate hårddisk på 1 TB.

Från Christoph Rutzer fick jag förslaget att sätta in en SSD disk när jag berättade om tanken på uppgradering. Christoph säger: *A good idea! I use here a Mac Mini for Mail/Internet/Audio. Some weeks ago I think the Mac is soo slow - I talk to my specialist for a new RAM (8GB) He says: No dont buy greater RAM; buy a SSD! So I have now a 500 GB SSD for 70 Euro, back-up the old HD and copy all data to the new SSD. (Thats very easy on a Mac).*
Now the Mini is VERY fast, and you do not hear anything. Thats the best idea!

Så det blev till att beställa en SSD disk. Samtidigt med installationen av denna gjordes en nyinstallation av operativsystemet till Win 7- 64 bitars. Fortfarande bara med 4 GB minne installerat. Win 7 64-bitars med Office 2007 samt Adobe CS2 svit + en del andra mindre program tar lite mindre än 60 GB.

När det gäller att fylla en SSD, så för absolut optimal prestanda och detta gäller i princip alla SSD, så gäller max 75%. Men då pratar vi om sådana extrema skrivningar som återigen en normal användare inte kommer i närheten av. I förhållande till storlek jämfört med en traditionell hårddisk är priset för SSD per MB väldigt högt. De datakunniga rekommenderar att man har en SSD som systemdisk på såg absolut minst 120GB för operativsystem och utvalda programinstallationer och en vanlig hårddisk för lagring av filmer, foton, musik etc. och kanske även vissa programinstallationer.

Man skall vara klar över att det är mycket drivrutiner och sen program som måste installeras på nytt om inte diskarna kan klonas. Sådant får man finna sig i. Det är en stor fördel att plocka hem drivrutiner till datorn innan man sätter igång. Eller som jag gjorde, kopplade in den firma som servar oss på jobbet. Dyrare men de har kunskapen och fixar ev. problem lätt.

Blev det någon skillnad? I mitt fall blev datorn som den vore nyköpt. En oerhört mycket snabbare dator blev det och som det ser ut nu så har problemen med uppspelningarna av Perseus filerna helt försvunnit när man kör dem från SSD-disken. Testade också att flytta filerna till den gamla hårddisken. Även här var det helt problemfritt med avlyssningen. Flyttningen av sju Perseus filer = 25 GB gick snabbt. Det tog c:a 5 minuter och hastigheten låg runt 75-80 MB/sek. Tidigare låg hastigheten bara på en tredjedel av detta.

Kollade processorbelastningen vid inspelning med största frekvensspann via Mestor och den ligger på mellan 0 och 1%.

En massa nyttig info finns på denna sida: <http://www.hongkiat.com/blog/solid-state-drives-upgrade/>
(Thomas Nilsson)

10m beacons mm.

Beacons är ett mycket trevligt DX-område för avancerade DX-are. Man behöver inte kunna CW, det räcker med att ha morsealfabetet tillgängligt för att kunna identifiera stationerna. Listor finns också flera, riktigt goda, som underlättar. Amatör-beacons finns hela vägen från MV (omkring 500 kHz) upp till VHF-området.

Roligast är som Arvid nämner de på 28 MHz. De kan höras året om, beroende på condx och speciella vågutbredningsförhållanden som Es, aurora, scatter och annat, som gör det extra fascinerande. Och QSL är inte svåra att få. Listor ja. Två helt aktuella finns: Den första har bara med HF (från 1.8 MHz) men ger info om sändarna.

<http://www.keele.ac.uk/depts/por/28.htm>

Den andra ger aktuella rapporter om beacons på samtliga band. Här har jag länk till 10 m, men du klickar bara på det band du väljer så kommer du rätt.

<http://hamradio.pl/beacons/?band=10m>

Det finns hundratals beacons att lyssna efter.... Kanske blir detta den stora flugan inom DX-lyssningen? Den har goda förutsättningar.

(73, Ullmar, SM5-1252)

1986 and 1991 Perseus files

The following Perseus format files dubbed from videotape RF captures are now available:

1 MAY 1986, 0759-0801 UTC, 410-2010 kHz (Craig Healy - metro-Providence, RI, USA)

http://chowdanet.com/markc/19860501_0759-0801z_410-2010.wav

2 APR 1991, 0759-0801 UTC, 810-1610 kHz (Mark Connelly - metro-Boston, MA, USA)

http://chowdanet.com/markc/19910402_0759-0801z_810-1610.wav

These were reduced to 2 minutes each from longer files by use of the Chuck Hutton 'WavChopper' program.

Earlier information on the topic appears below.

(Mark Connelly, WA1ION, South Yarmouth, MA, USA)

Earlier posts:

I finally got around to going through a box of VHS videotapes from the late '80s / early '90s spectrum capture experiments, as originally developed by Craig Healy (NG1U), and mentioned in this article:

<http://chowdanet.com/markc/webpage/WA1ION/vcrdx.pdf>

There were about 6 tapes in the box. Two of these, when played into a receiver, had reasonable performance.

One of these was the tape Craig had originally supplied me. This was made at his QTH near Providence, RI. The whole AM band is captured. Sensitivity on the lower half was quite low so it's primarily the local stations such as 630, 790, and 920. Some skip signals can be heard on the upper half of the dial. I still have to review the tape to determine the exact date and times of recording. Items on a news / sports station, possibly with some Google follow-up, will nail down the date. At some point in the recording there should be a time check on one station or another. I looked into the lower shortwave spectrum but noted little in the way of "real" (non-birdie) signals, so no CHU or WWV assistance on the time.

The second tape was one I made at Billerica, MA in April 1991 during the "wee hours" of the morning: 0643-1043 UTC. Because 50 kW WRKO on 680 is only 2.8 miles / 4.5 km from the receiving site, a notch filter for 680 was inserted ahead of the VCR input. Usable sensitivity for the capture came in starting around 800 kHz and up.

One thing that must be kept in mind is that this primitive version of spectrum capture had a rather small dynamic range: only about 30 to 40 dB from a hashy noise floor up to the level of a strong local on the verge of causing distortion and spurs. The tapes, obviously, are not going to produce much in the way of weaker signal DX.

Before the tapes have a chance to deteriorate, I'm porting at least some of the contents over to Perseus files. This also gives a ready method for sharing the experiment results with others. I reset the computer date/time so that the Perseus time-stamping is relatively close to the occurrence of the original recordings.

After I get all this stuff digitized, I'll go over it for any interesting audio clips.

Though the "VCR DX" method became known to the MW DX world about a quarter century ago, it is widely believed that, as far back as the JFK administration, "spook" agencies such as the NSA were able to store substantial RF bandwidths for later review. Broadcast studio grade videotape, or something similar but custom-designed, was used. Converters allowed any chunk of spectrum to be heterodyned to the baseband range (0-3 MHz?) the tapes could accommodate. The late Gordon Nelson (WAIUXQ) seemed aware of it. Maybe some tapes will show up at a Fort Meade, MD flea market / yard sale so we can tune around and hear stuff like Belize 834 and Bermuda 1235 once again, as well as Murray-the-K on WINS proclaiming his status as the Fifth Beatle.

(Mark Connelly, WAIION, South Yarmouth, MA)

OK, let me understand this... the idea was to take 0-150MHz add a 60Hz sync signal to keep the VCR happy, store it to tape through the Video IN jack then on output simply remove the 60Hz and you basically have coming out what you put in? So simple its silly! I once used a Hi-Fi VCR to capture 8 hours of FM DX audio. Hardly genius.

(Bill Nollman)

That's basically it Bill, though I think that 2 MHz would be about the top of the baseband range. Storing higher frequency blocks would require a downconverter stage. That, as far as I know, was the intelligence agencies' method employed at places like Menwith Hill (UK), Resolute Bay (Canada), Thule (Greenland), Incirlik (Turkey), the Aleutian Islands, and numerous other monitoring outposts in the '60s to snoop on the Russian bear (and probably the ChiCom's too).

Regarding Craig's comment, I have identified that his recording starts at 0859 UTC on 1 MAY 1986. Lots of news about the Chernobyl nuclear reactor accident a few days earlier. Fun to hear 1560 WQXR doing classical, as well as hearing contemporary hit music and oldies on numerous other stations that are now boring talk ... aah the good old days! No TA's or Latin Americans, but what do you want with only about 40 dB of dynamic range?

So, besides my 1991 stuff, now we have Perseus files from 1986!

(Mark Connelly, WAIION South Yarmouth, MA)

I have converted the two best spectrum capture videotapes (1986, 1991) to Perseus files and then dubbed off a few ID's with Total Recorder. This is what I have so far:

http://chowdanet.com/mark/dx_audio/id1_19860501_0500e.mp3

ID's 5 a.m. EDT / 0900 UTC, 1 MAY 1986 from metro-Providence, RI (Craig Healy VCR DX spectrum capture tape): WWKB-1520 NY, WTOP-1500 DC, WPTR-1540 NY, WQXR-1560 NY, WCAU-1210 PA, WRCP-1290 RI, WHIM-1110 RI, WHJJ-920 RI, WHN-1050 NY, WINS-1010 NY.

http://chowdanet.com/mark/dx_audio/id1_19910402_0500e.mp3

ID's 5 a.m. EST / 1000 UTC, 2 APR 1991 from Billerica, MA (Mark Connelly VCR DX spectrum capture tape): WHDH-850 MA, WCAP-980 MA, WBZ-1030 MA, WADN-1120 MA, WNEW-1130 NY, WMJX-1150 MA (ID for FM), WKOX-1200 MA, WEZE-1260 MA, WJDA-1300 MA, WRCA-1330 MA, WFEA-1370 NH, WLLH-1400 MA, WXKS-1430 MA, WTOP-1500 DC, WSSH-1510 MA, WQXR-1560 NY.

(Mark Connelly, WAIION, South Yarmouth, MA)

I am fascinated by the conversion of a broadband vhs tape recording to a Perseus file. Well done.....

So aligned freq for both, set PC date back, and played into perseus aerial socket and press record?? Is that how it was done??? And it worked???? Any chance of posting a 5m or so toth Perseus file somewhere??? For 1986 and 1991....???

Night time files would be of interest as well...

(Ken, Scotland)

(All items from Perseus_SDR)